

# Alphabet Activities

## Book 4

### Sound and Word Development

Written by Kerry Heathcote & Kathryn Bryce. © Ready-Ed Publications - 2006.  
Published by Ready-Ed Publications (2006) P.O. Box 276 Greenwood Perth W.A. 6024  
Email: [info@readyed.com.au](mailto:info@readyed.com.au) Website: [www.readyed.com.au](http://www.readyed.com.au)

**COPYRIGHT NOTICE**

Permission is granted for the purchaser to photocopy sufficient copies for non-commercial educational purposes. However, this permission is not transferable and applies only to the purchasing individual or institution.

**ISBN 1 86397 660 4**

## Rationale

*Sound and Word Development* is the fourth in a four part series called *Alphabet Activities*. It is for use in an early literacy program. This fourth book provides teachers with a practical series of activity-based worksheets which expand the body of work set out in *Initial Sounds*, *Sound Jigsaws* and *Word Building* and *Sound and Word Building*. The worksheets provide children with the opportunity to identify sounds and words through a variety of exercises such as cut-and-paste, read and draw, true and false, matching words to pictures, labelling, unjumbling and rhyming. These activities foster, encourage and reinforce sound recognition, letter formation, letter-sound relationships, consonant blends, rhyming, word building, sight vocabulary and fine motor skills. They have been designed to motivate students to develop and learn.

## About the Authors

Kerry Heathcote has 36 years teaching experience in Early Childhood in Queensland, New South Wales and Victoria.

Kathryn Bryce is a graphic designer with a Bachelor of Arts (Hons.) degree majoring in Communications. She has worked as a tutor with both children and adults with learning disabilities.

## Curriculum Links - Links to Achievement Objectives

### English - Level 1

### Reading

**Personal Reading** - Students will begin to use semantic, syntactic, visual, and grapho-phonetic cues to gain meaning.

**Close Reading** - Students will respond to language and meanings in texts.

### Reading Processes

**Exploring Language** - Students will explore choices made by writers, and identify and use the common conventions of writing and organisation of text which affect understanding.

## Beginning Sounds: Exercise 10

Name: \_\_\_\_\_

Write the starting sounds.

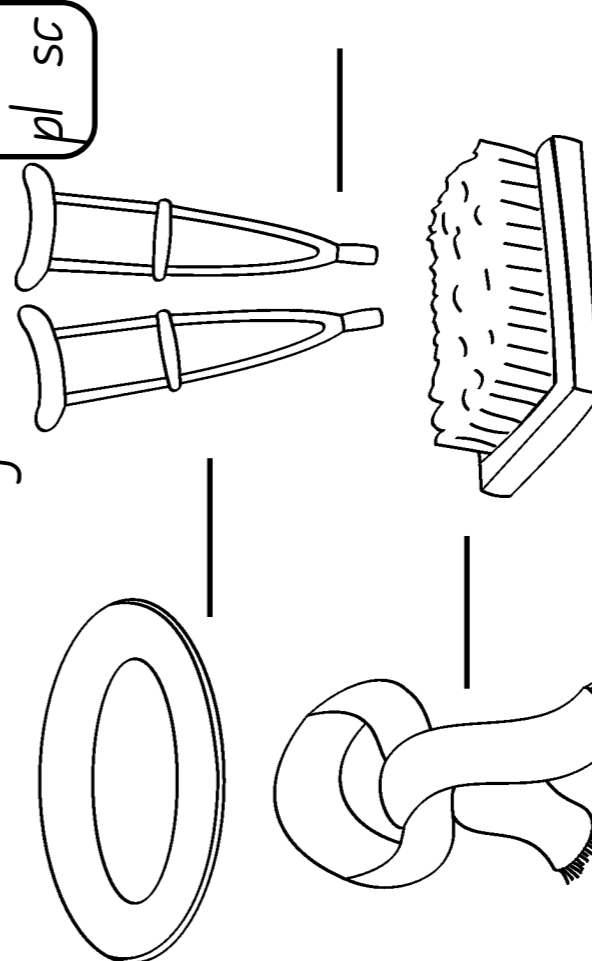

Circle the correct starting sound.

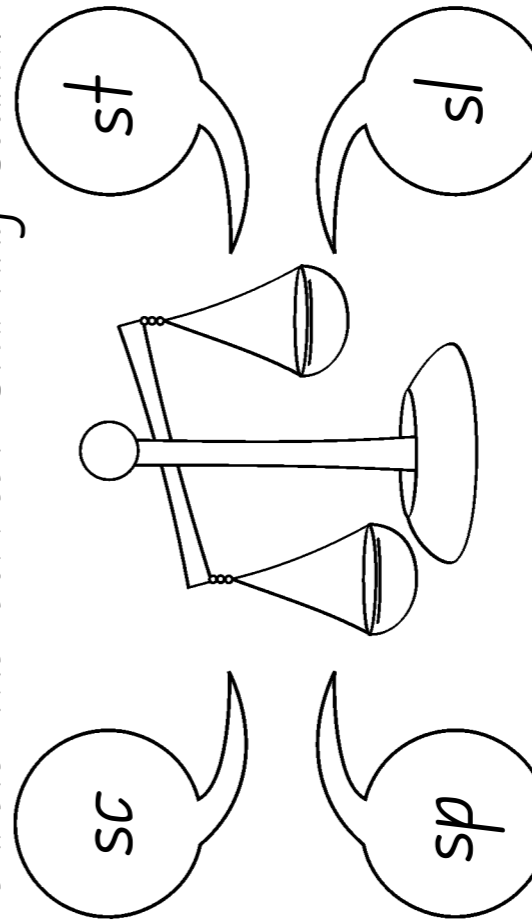

Add **cr** and draw the picture:

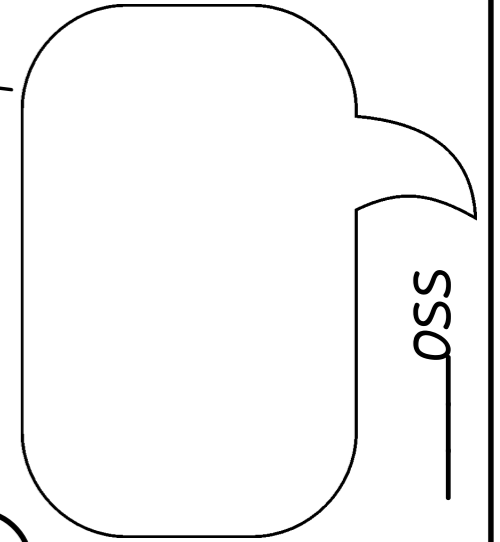

Which word matches the picture?

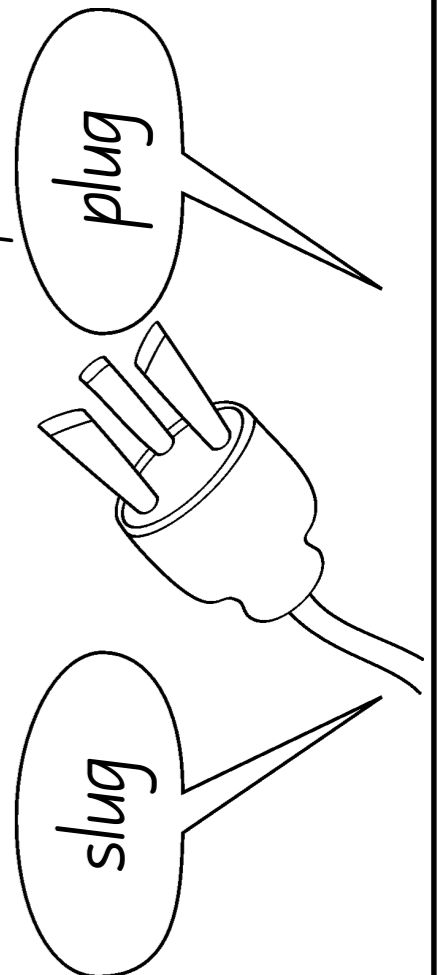

# Beginning Sounds: Exercise 9

Name: \_\_\_\_\_

Write the starting sounds. \_\_\_\_\_

cr fr  
sp st

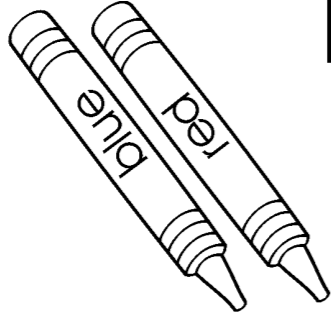
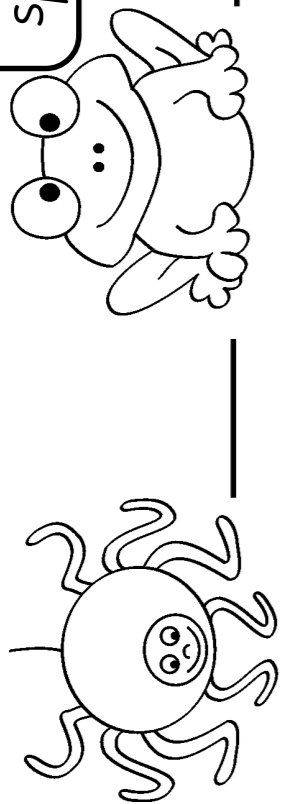

Which word matches the picture? \_\_\_\_\_

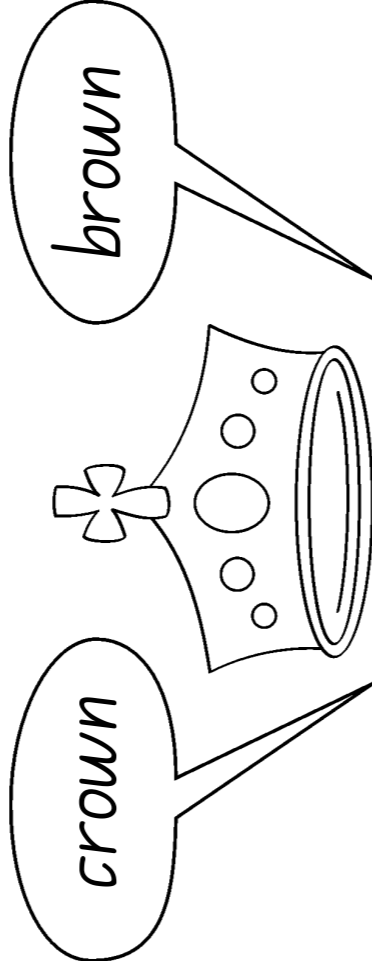

crown

brown

Circle the correct starting sound.

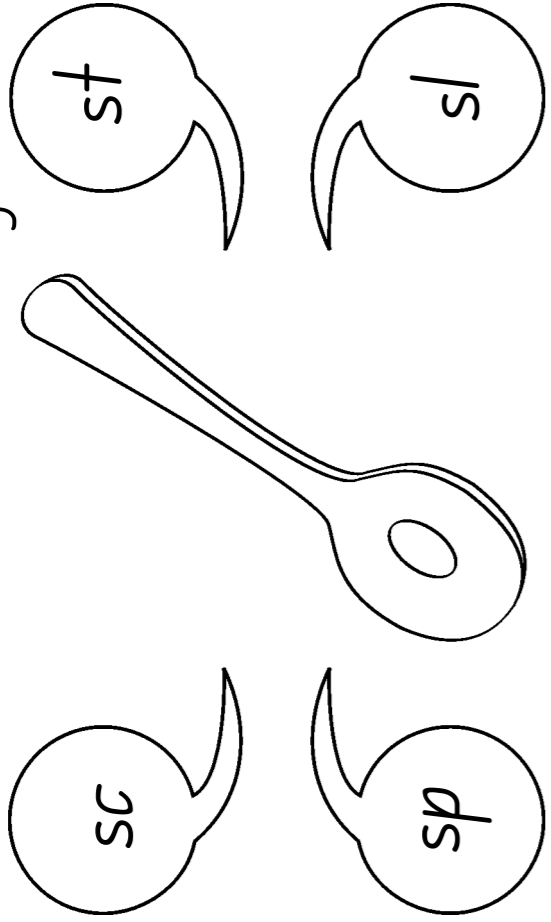

Add **st** and draw the picture: \_\_\_\_\_

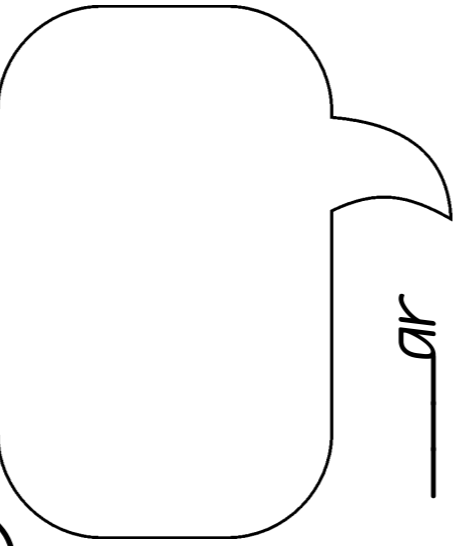

## Contents

### Middle Sounds

Middle Vowel: **a** ..... page 4  
 Middle Vowel: **e** ..... page 5  
 Middle Vowel: **i** ..... page 6  
 Middle Vowel: **o** ..... page 7  
 Middle Vowel: **u** ..... page 8

### Fun Middle Sound Activities ..... pages 9-31

Activities include:

- Write the Middle Sound
- Write the Word
- Unjumble the words
- Rhyming Words
- Read and Draw
- True and False
- Word Matching

### Sound Blends

Beginning Sounds: **bl** ..... page 32  
 Beginning Sounds: **cl** ..... page 33  
 Beginning Sounds: **gl** ..... page 34  
 Beginning Sounds: **pl** ..... page 35  
 Beginning Sounds: **sp** ..... page 36  
 Beginning Sounds: **st** ..... page 37  
 Beginning Sounds: **tr** ..... page 38  
 Beginning Sounds: **ch** ..... page 39  
 Beginning Sounds: **sh** ..... page 40  
 Beginning Sounds: **wh** ..... page 41  
 Beginning Sounds: **th** ..... page 42

Fun Mixed Exercises: **ch** ..... page 43  
 Fun Mixed Exercises: **sh** ..... page 44  
 Fun Mixed Exercises: **wh** ..... page 45  
 Fun Mixed Exercises: **th** ..... page 46

Beginning Sounds: Exercise 1 ..... page 47  
 Beginning Sounds: Exercise 2 ..... page 48  
 Beginning Sounds: Exercise 3 ..... page 49  
 Beginning Sounds: Exercise 4 ..... page 50  
 Beginning Sounds: Exercise 5 ..... page 51  
 Beginning Sounds: Exercise 6 ..... page 52  
 Beginning Sounds: Exercise 7 ..... page 53  
 Beginning Sounds: Exercise 8 ..... page 54  
 Beginning Sounds: Exercise 9 ..... page 55  
 Beginning Sounds: Exercise 10 ..... page 56

# Middle Sounds

Name: \_\_\_\_\_

Write the middle sound for each picture.

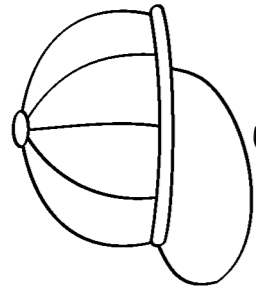

c \_ p

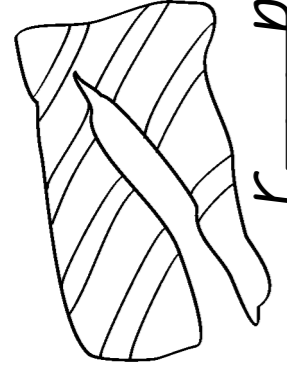

r \_ p

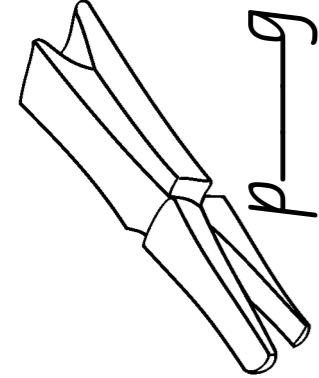

p \_ g

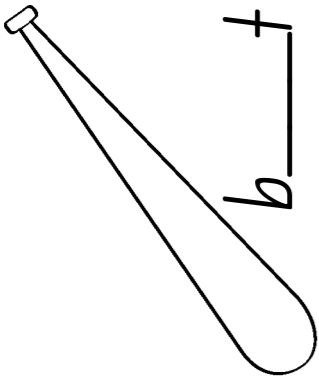

b \_ t

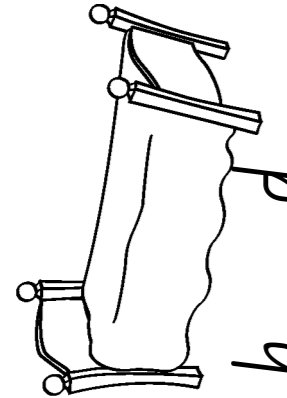

b \_ d

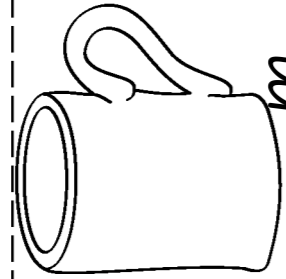

m \_ g

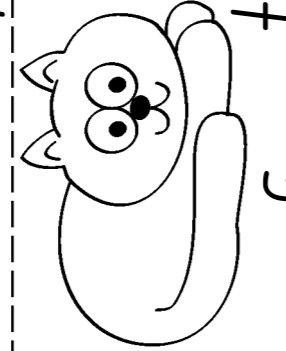

c \_ t

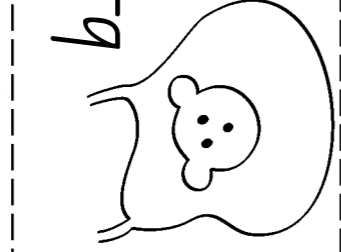

b \_ b

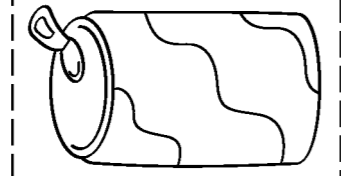

c \_ n

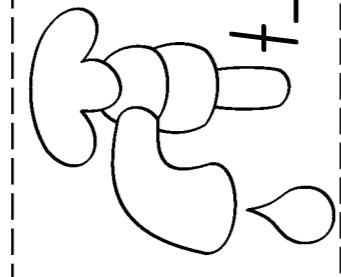

h \_ t \_ p



Paste the pictures that have a **O** as the middle sound below:

<b>a</b>	<b>a</b>	<b>a</b>	<b>a</b>
----------	----------	----------	----------

# Beginning Sounds: Exercise 8

Name: \_\_\_\_\_

Write the starting sounds.

dr pl  
sp th

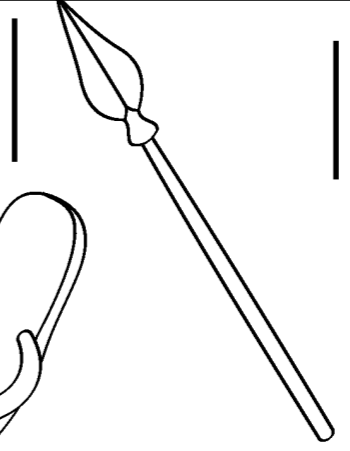
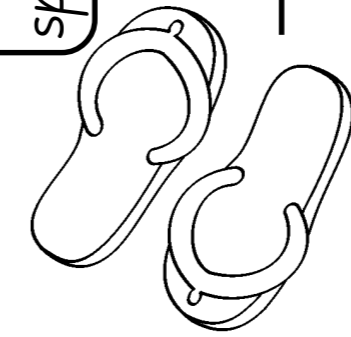
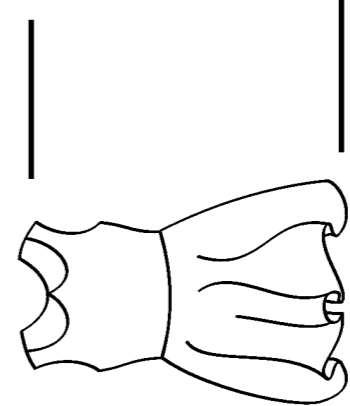
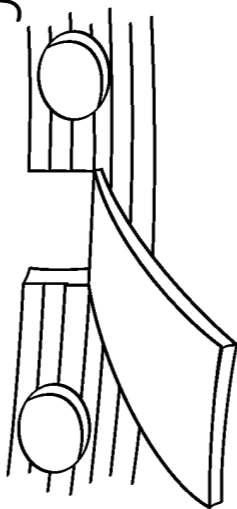

Circle the correct starting sound.

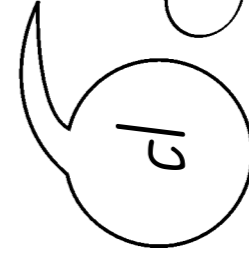
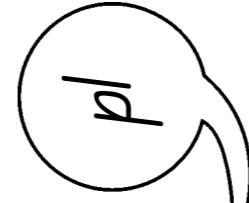
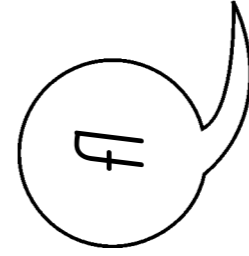

Which word matches the picture?

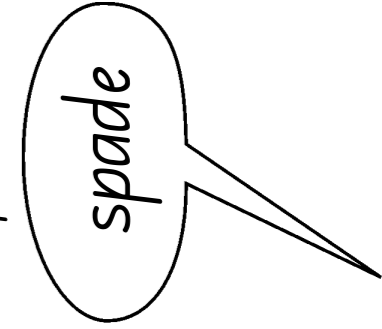
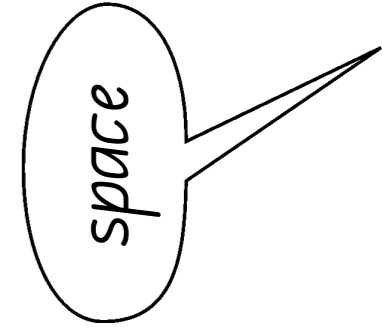

plate	late	play	plug
plus	plane	plot	lot
plan	pluck	duck	place

Which words do not start with **pl**?

# Beginning Sounds: Exercise 7

Name: \_\_\_\_\_

Write the starting sounds.

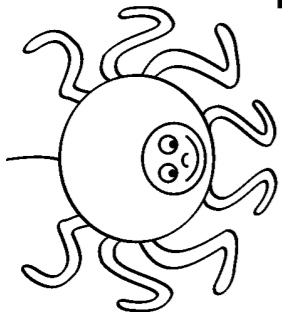

cr fl  
gl sp

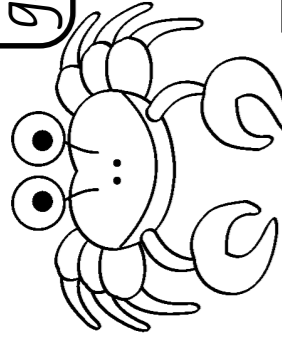

\_\_\_\_\_

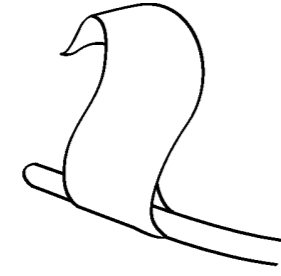

\_\_\_\_\_

\_\_\_\_\_

\_\_\_\_\_

cr

ch

cl

st

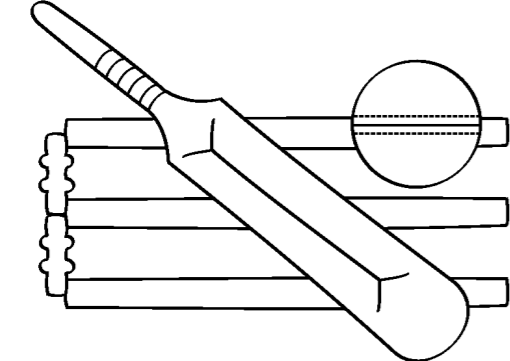

Circle the correct starting sound.

Which word matches the picture?

flat

fly

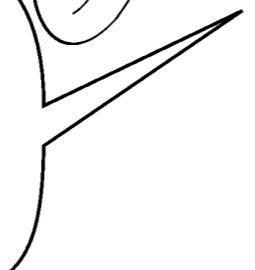
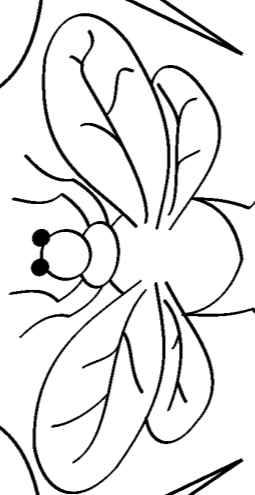

Which words do not start with **sp**?

spy spin span pan

space pace spot spit

sell spell spill sport

# Middle Sounds

Name: \_\_\_\_\_

Write the middle sound for each picture.

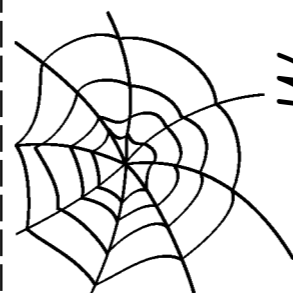

w\_b

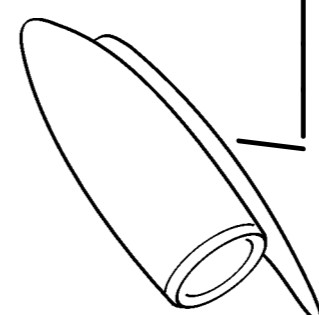

l\_d

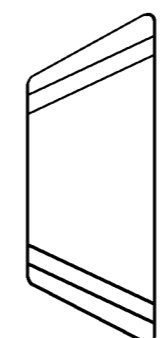

p\_n

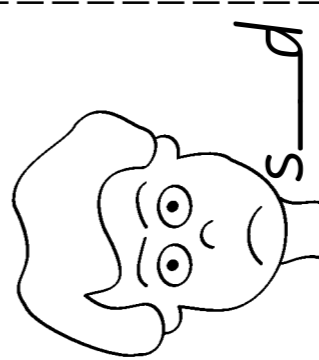

s\_d

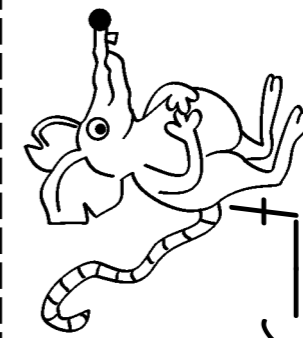

r\_t



h\_n

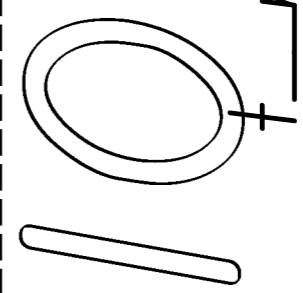

f\_n

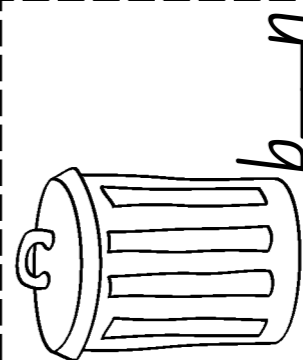

b\_n

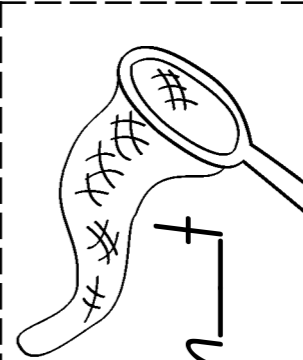

n\_t



Paste the pictures that have **e** as the middle sound below:

e

e

e

e

e

# Middle Sounds

Name: \_\_\_\_\_

Write the middle sound for each picture.

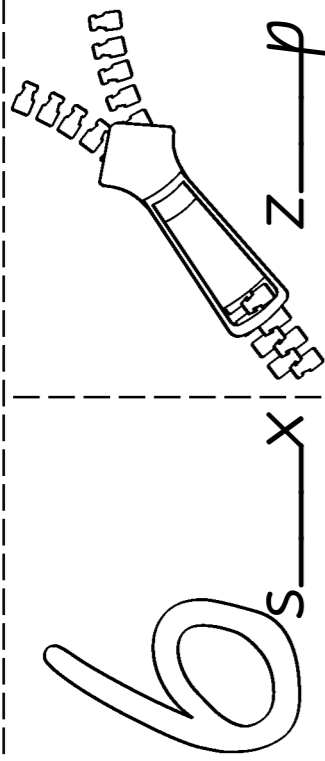

z \_ p

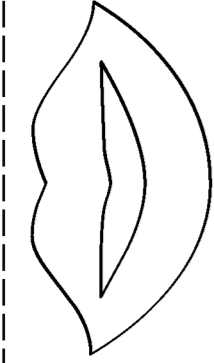

l \_ ps



m \_ p

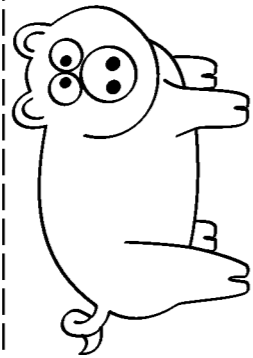

p \_ g

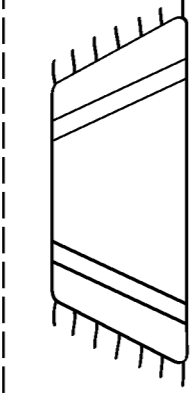

m \_ t

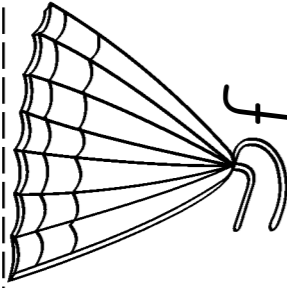

f \_ n

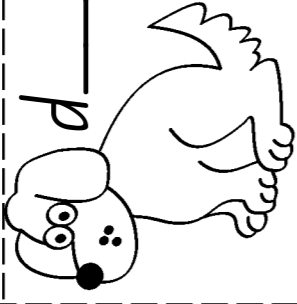

d \_ g

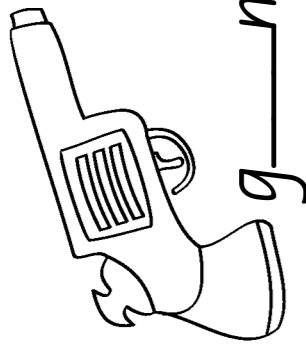

g \_ n

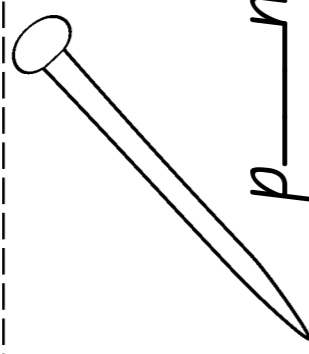

p \_ n



Paste the pictures that have **i** as the middle sound below:

<b>i</b>	<b>i</b>	<b>i</b>	<b>i</b>
----------	----------	----------	----------

# Beginning Sounds: Exercise 6

Name: \_\_\_\_\_

Write the starting sounds.

br cl  
dr tr

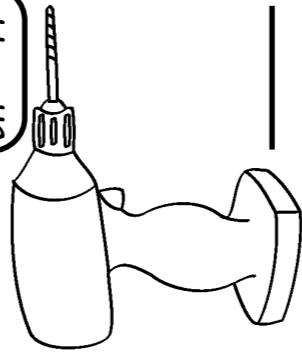
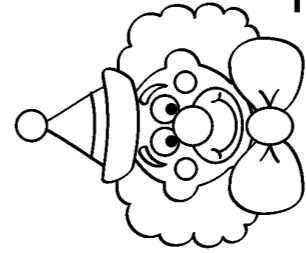
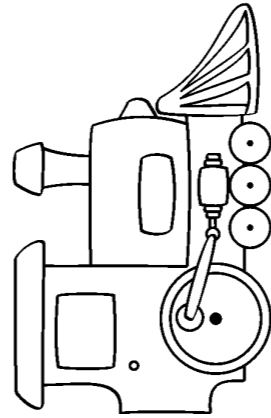

Which word matches the picture?

broom

bread

Circle the correct starting sound.

br



bl

dr

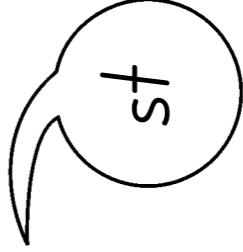

st

Which words do not start with **tr**?

try fly true trap

whip trip trot trim

trunk truck tree free

# Beginning Sounds: Exercise 5

Name: \_\_\_\_\_

Write the starting sounds.

cr sk  
pr st

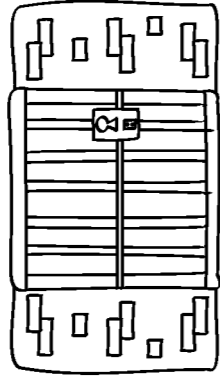
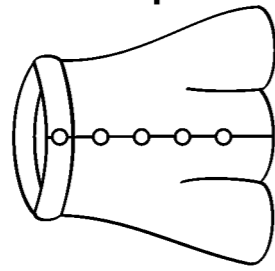
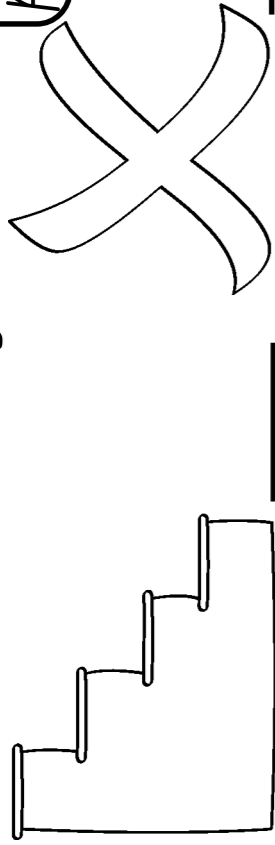

cr

cl

ch

sl

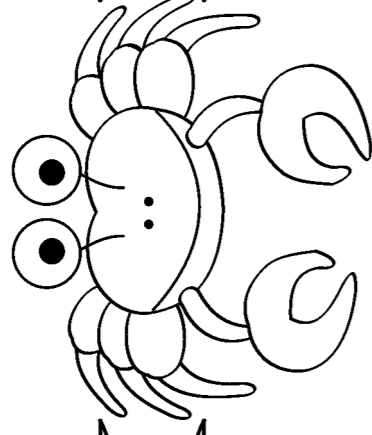

Circle the correct starting sound.

Which word matches the picture?

start

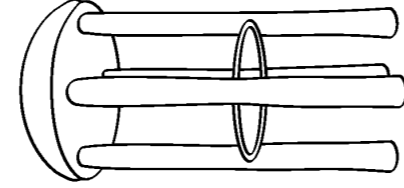

stool

Which words do not start with sk ?

sky fly ski skirt

skin skid slid skill

slate skate skim skip

# Middle Sounds

Name: \_\_\_\_\_

Write the middle sound for each picture.

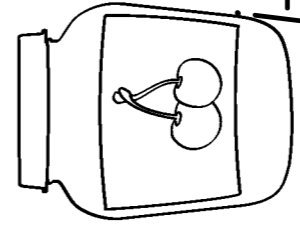

j \_ m

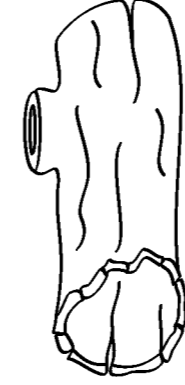

l \_ g

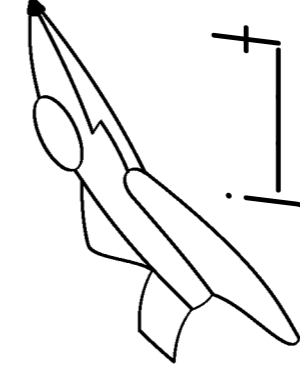

j \_ t

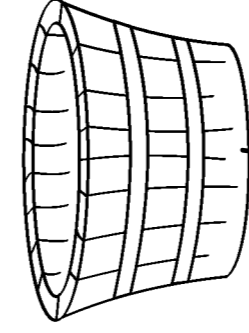

t \_ b

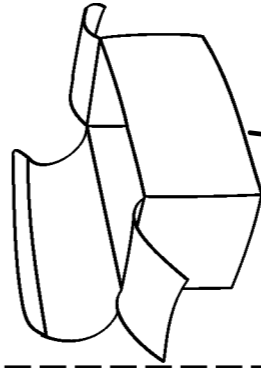

b \_ x

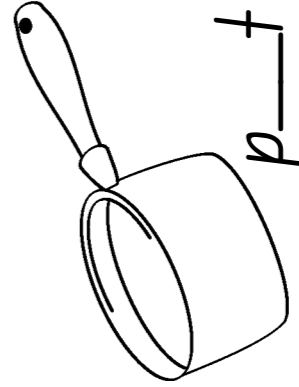

p \_ t

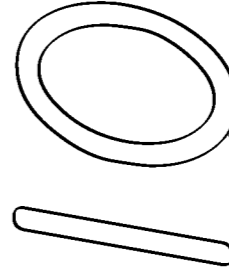

t \_ n



f \_ x

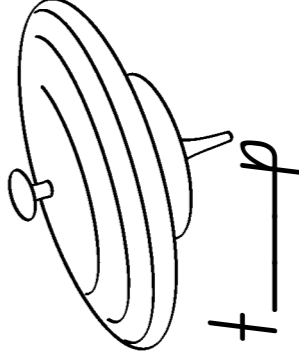

t \_ p

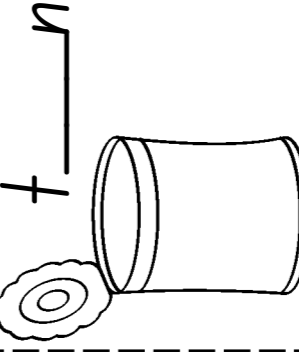

t \_ n



Paste the pictures that have  as the middle sound below:

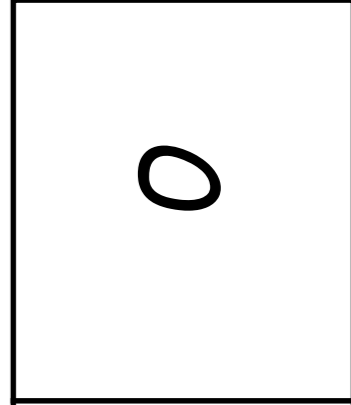
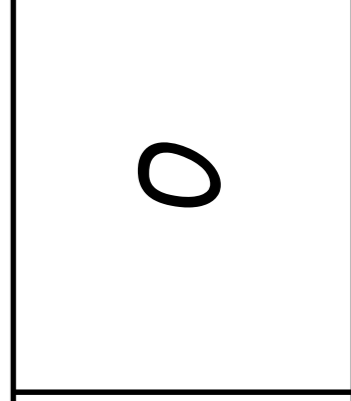
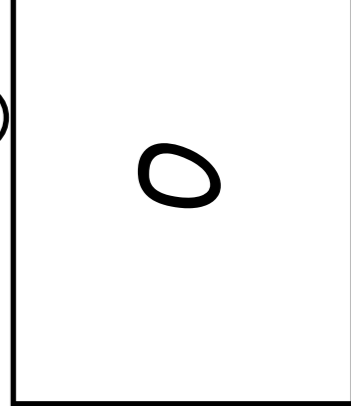
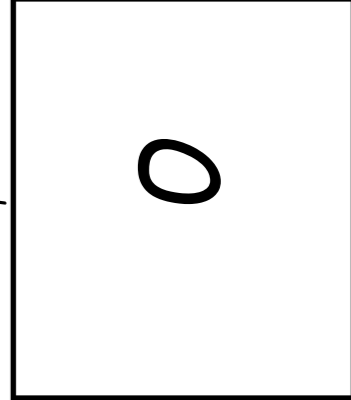
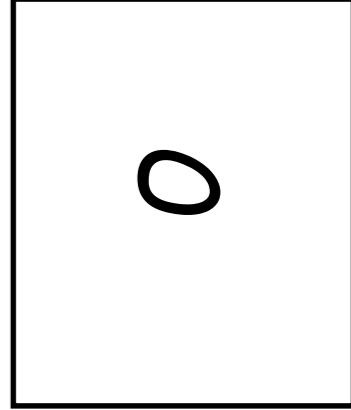

# Middle Sounds

Name: \_\_\_\_\_

Write the middle sound for each picture.

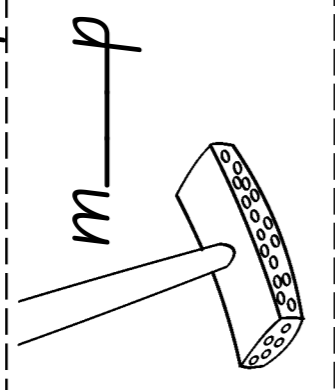
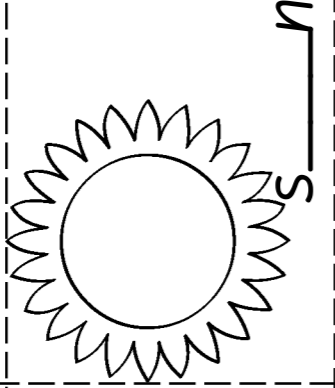
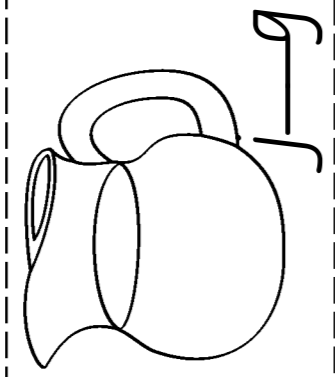
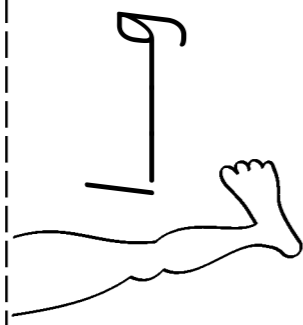
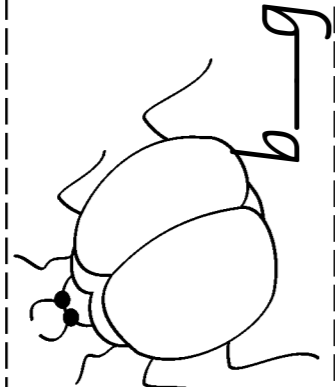
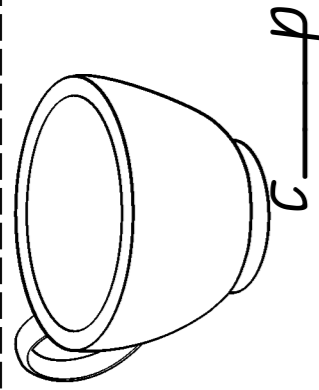
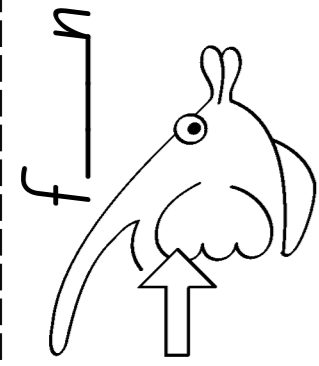
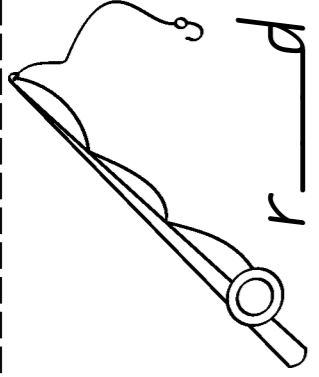
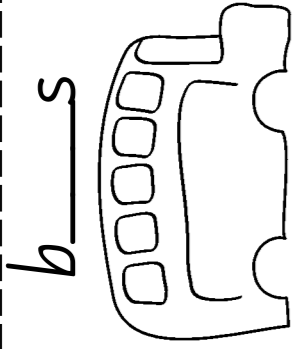
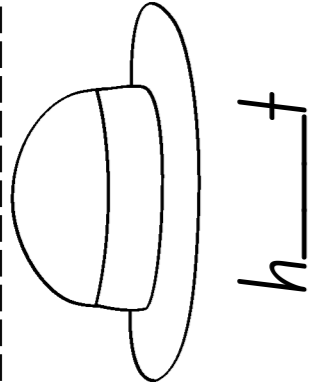

Paste the pictures that have u as the middle sound below:

u	u	u	u
---	---	---	---

# Beginning Sounds: Exercise 4

Name: \_\_\_\_\_

Write the starting sounds.

gr pl  
sl tr

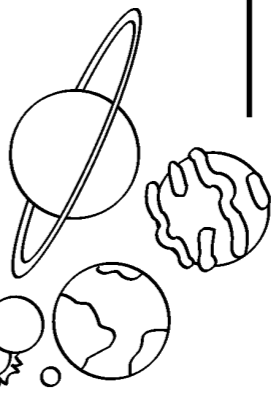
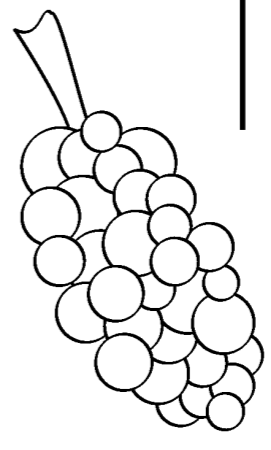
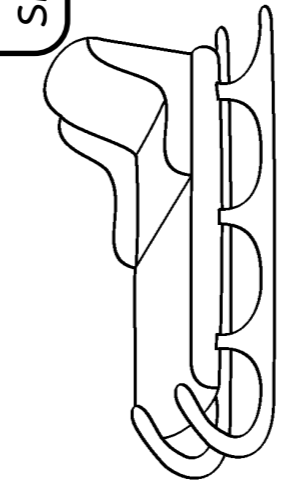
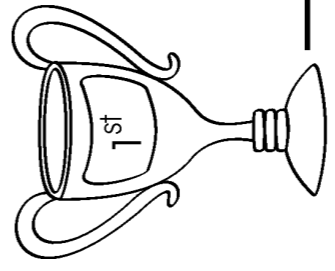

Which word matches the picture?

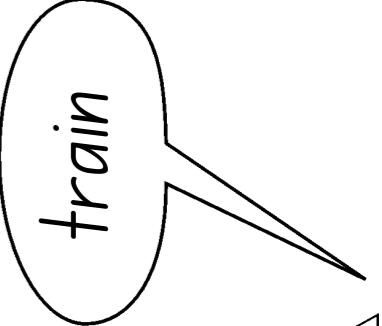
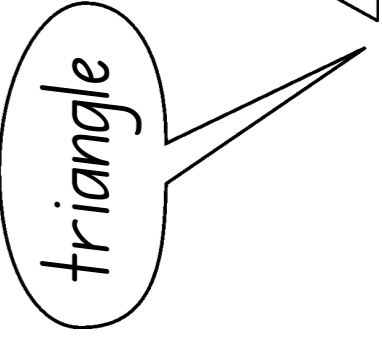

Add tr and draw the picture:

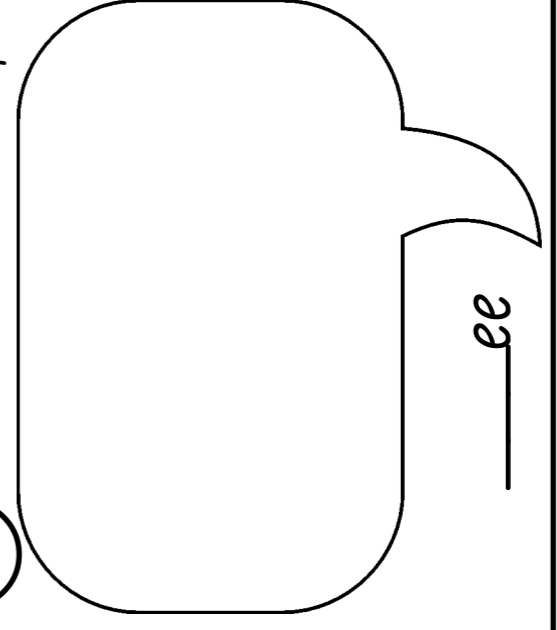

Which words do not start with sl?

- slip flip slop slap
- slab slam clam slate
- sled slice sleep sheep



# Beginning Sounds: Exercise 3

Name: \_\_\_\_\_

Write the starting sounds.

fl fr  
pr sk

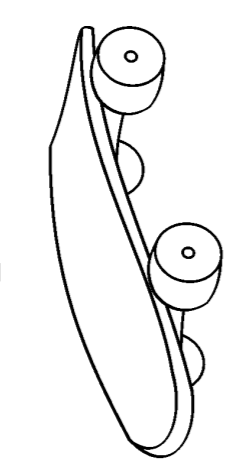
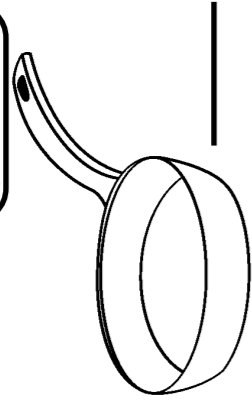
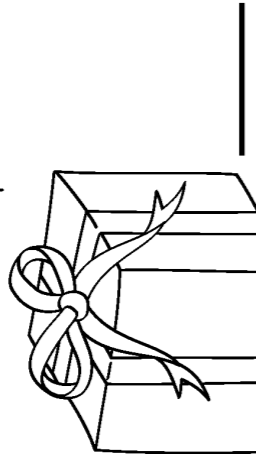
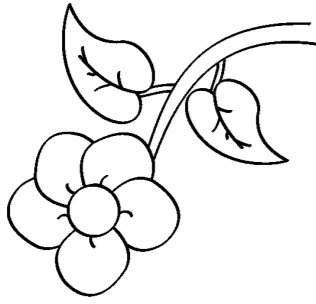

Which word matches the picture?

plum

pram

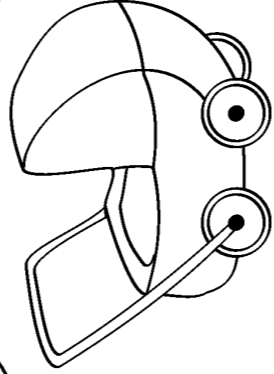

Circle the correct starting sound.

sc

ch

sh

st

Which words do not start with fl ?

flop fly sly flee

flip slip flat fled

clop flop flew flash

# Fun Middle Sound Activities

Name: \_\_\_\_\_

Write the middle sound for each picture.

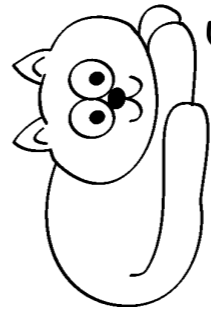

c \_ t



w \_ g



p \_ n

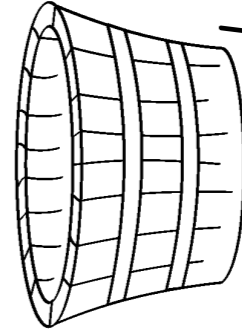

t \_ b

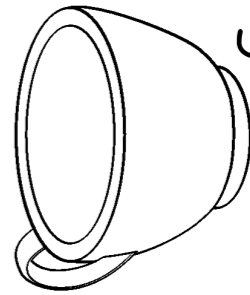

c \_ p

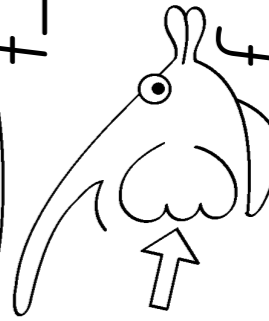

f \_ n

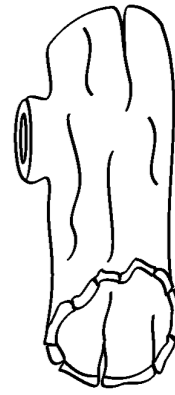

l \_ g



r \_ t

Unjumble the words.

amh

\_\_\_\_\_

pli

\_\_\_\_\_

nar

\_\_\_\_\_

Match the rhyming words.

wig

fun

bun

hot

vet

big

cot

wet

# Fun Middle Sound Activities

Name: \_\_\_\_\_

Write the middle sound for each picture.

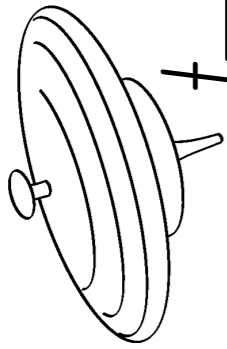

t \_ p

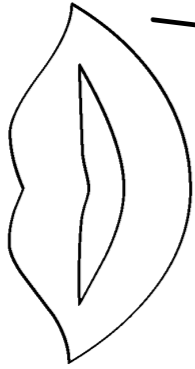

l \_ p

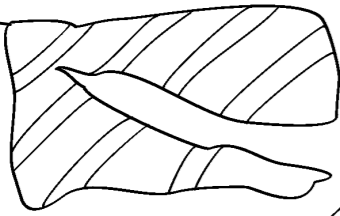

r \_ p

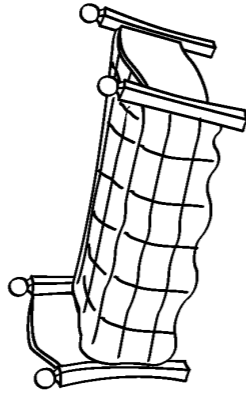

b \_ d

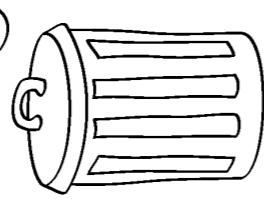

b \_ t

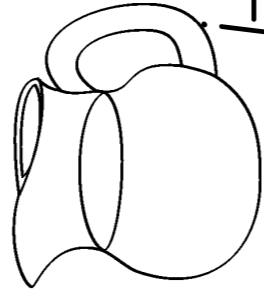

b \_ n

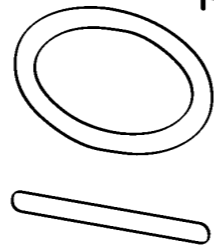

t \_ n

j \_ g

Can you find these words?

~~but~~ hit hug let sat not

b	s	a	h	u	g
u	h	e	i	l	u
t	s	a	t	i	l
	s	i	l	e	t
	n	o	t	h	o
					t

Read and Draw

A cat on a mat.

# Beginning Sounds: Exercise 2

Name: \_\_\_\_\_

Write the starting sounds.

bl cl

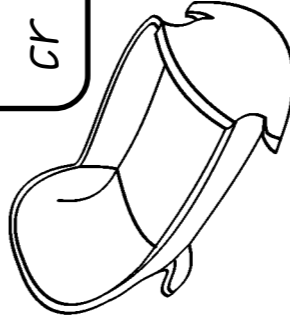

cr sn

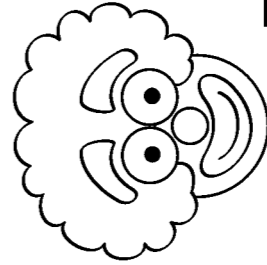
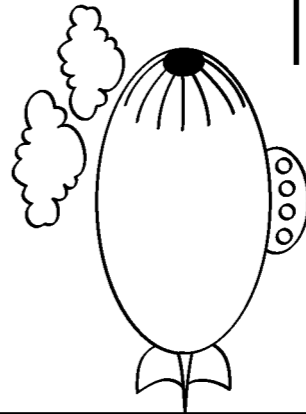

Which word matches the picture?

clam

clown

Can you find these **cr** words?

crab  
cram  
crib  
crop  
crow  
cry

c	r	o	w	c	r
r	c	c	r	a	m
c	<b>c</b>	<b>r</b>	<b>a</b>	<b>b</b>	
c	r	i	b	b	c
a	y	c	r	o	p

Which words do not start with **cl**?

close clean clam slam

class clap clip slip

clop flop clue claw

# Beginning Sounds: Exercise 1

Name: \_\_\_\_\_

Write the starting sounds. br dr  
gl sp

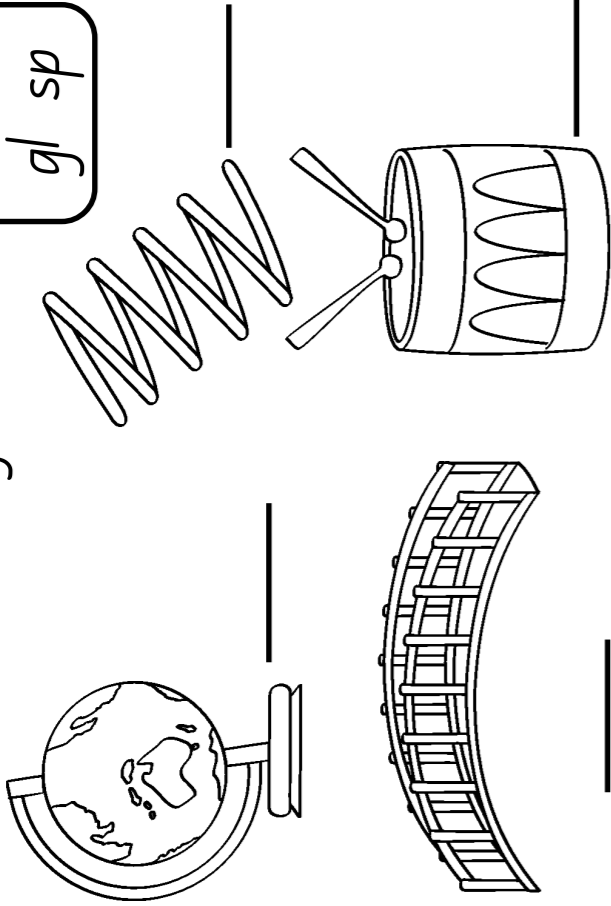

Which word matches the picture?

- thick
- brick
- slick
- click

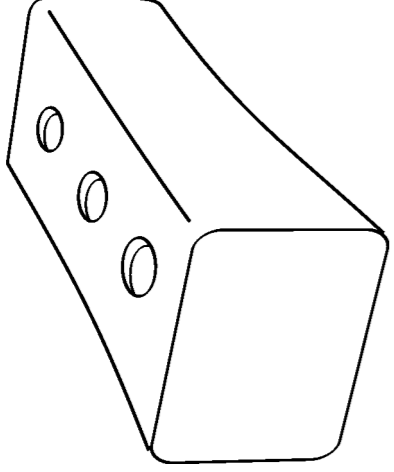

Which words do not start with **dr** ?

- draw drill dream brown
- bit drew drag drip
- drop boss dry dress

Which word matches the picture?

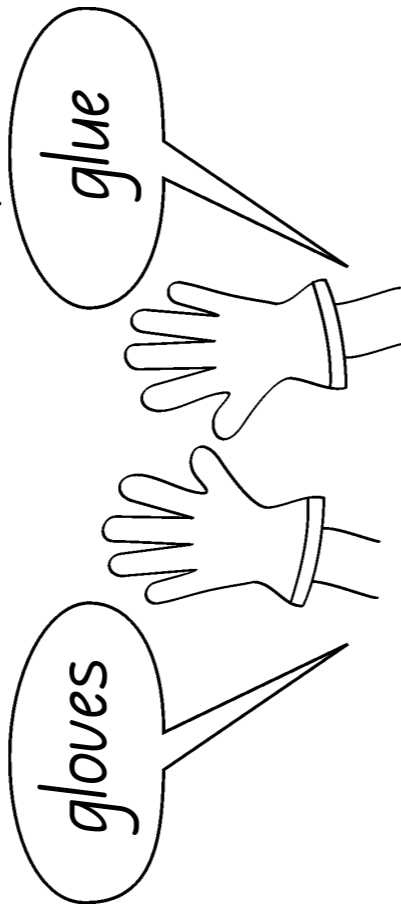

# Fun Middle Sound Activities

Name: \_\_\_\_\_

Write the middle sound for each picture.

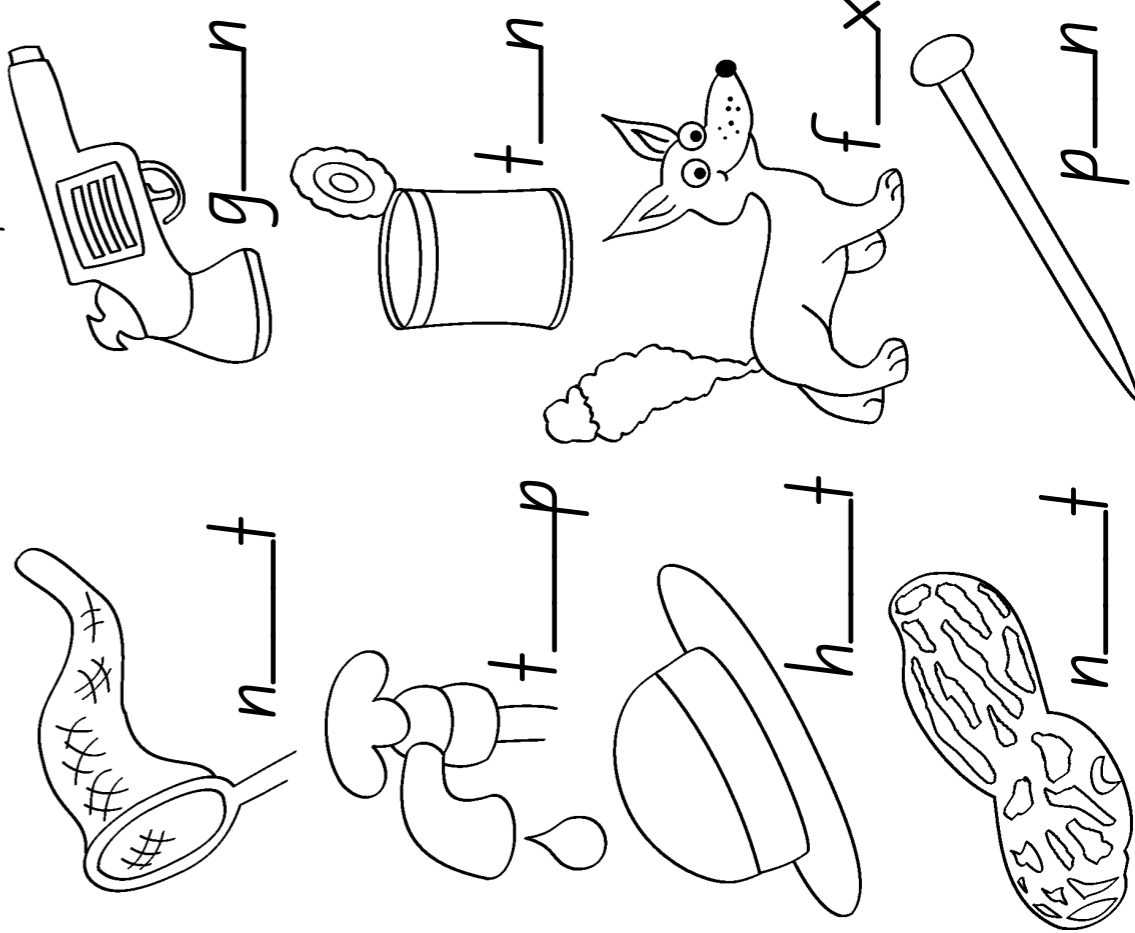

Draw a picture for each word.

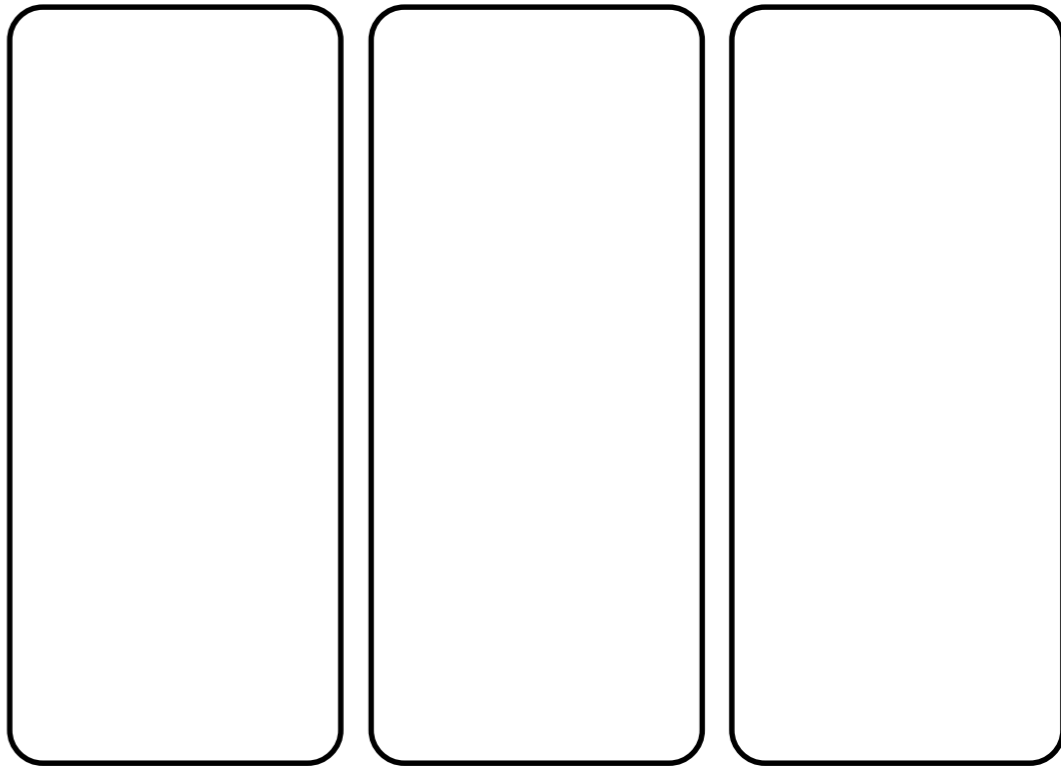

bed

pig

dog

# Fun Middle Sound Activities

Name: \_\_\_\_\_

Write the middle sound for each picture.



b \_ \_ x

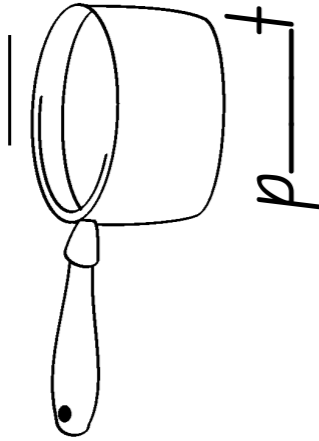

p \_ \_ t



h \_ \_ n

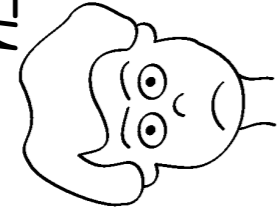

s \_ \_ d

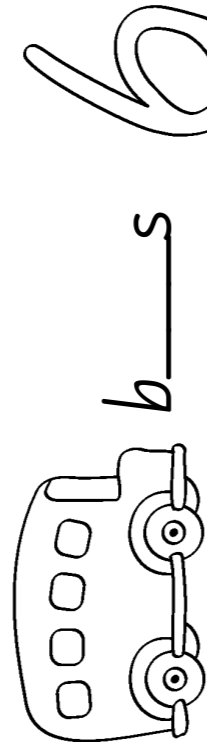

b \_ \_ s

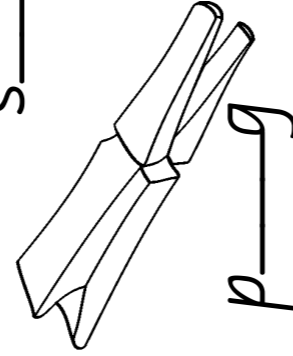

s \_ \_ x

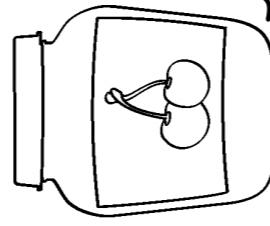

j \_ \_ m p \_ \_ g

How many words can you find?

\*Find words that have 3 letters\*

s	u	n	j	a	r
i	w	i	n	r	b
x	e	b	c	a	t
a	p	i	b	m	a
p	e	g	p	n	t

Which word matches the picture?



big  
fog  
dog  
dig

\_\_\_\_\_

# Fun Mixed Exercises: th

Name: \_\_\_\_\_

Write the starting sounds.

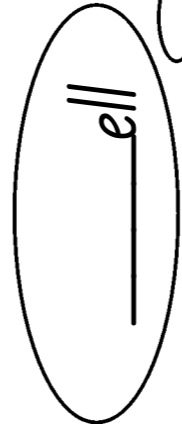

\_\_ell

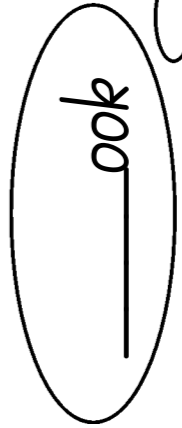
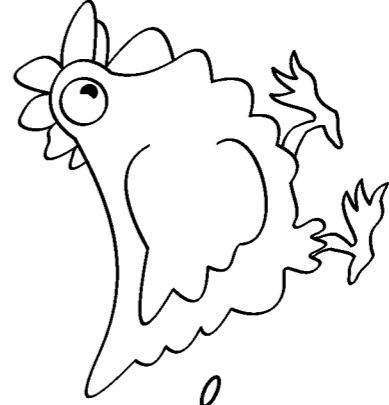

\_\_ook

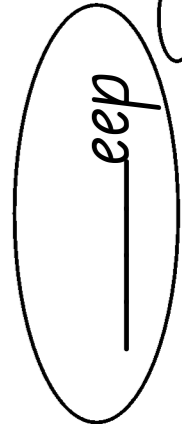
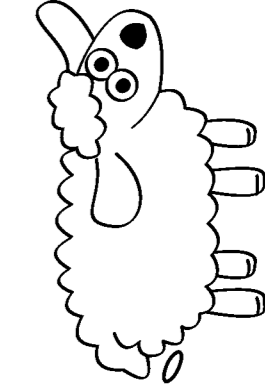

\_\_eep

Which words do not start with **th**?

the then with than

that path those thin

both thing them these

Can you find these **th** words?

them  
there  
they  
thick  
third  
this

t	h	e	m
t	h	e	y
h	i	s	t
i	s	t	h
r	t	h	e
d	t	h	i
		c	k

# Fun Mixed Exercises: sh

Name: \_\_\_\_\_

Which word matches the picture?

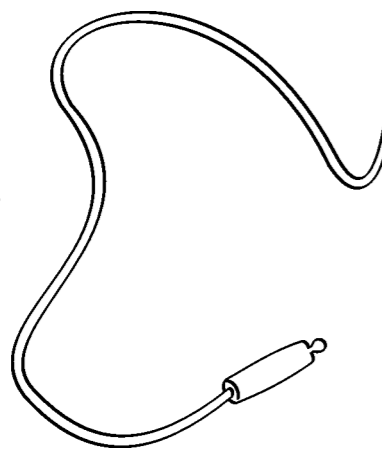

flip \_\_\_\_\_  
 whip \_\_\_\_\_  
 chip \_\_\_\_\_  
 ship \_\_\_\_\_

Which words do not start with **wh**?

why which hip whip  
 wheel who where we  
 when white hat what

Write the starting sounds for these pictures:

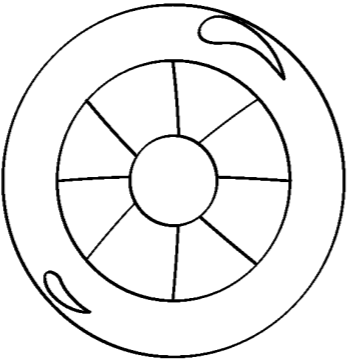

    eel

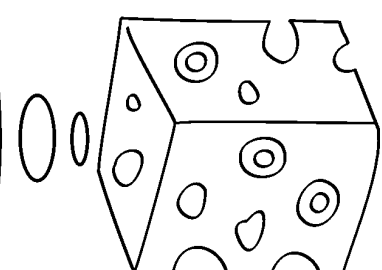

    ese

Write the starting sounds for these pictures:

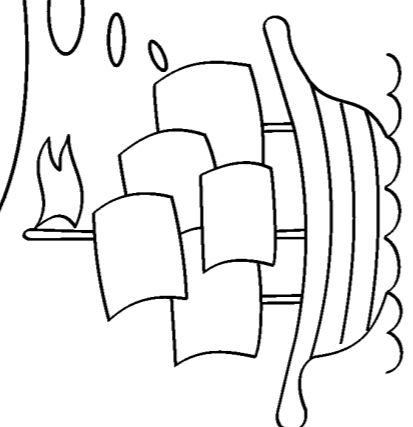

    ip

# Fun Middle Sound Activities

Name: \_\_\_\_\_

Write the middle sound for each picture.

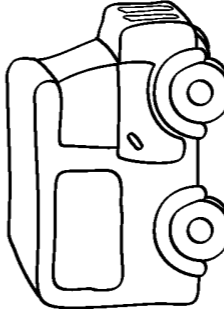

    n

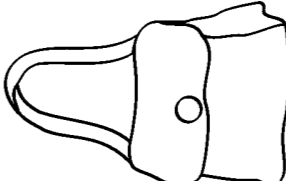

b    g

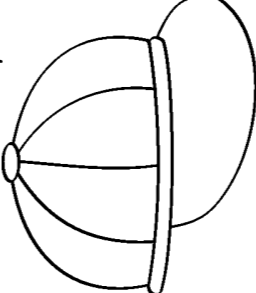

    p

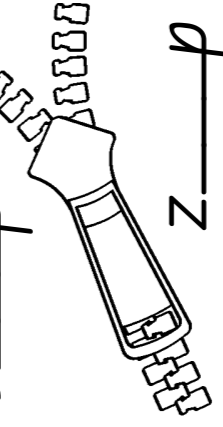

    p

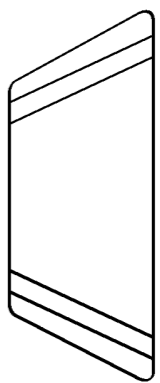

    t

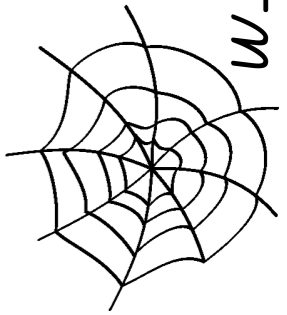

r    g



b    g

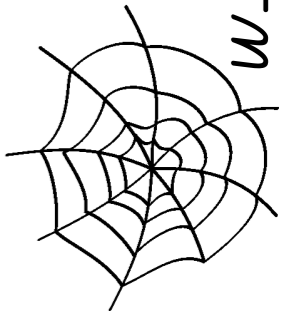

    w    b

Can you find these words?

~~hip~~ mug pat peg run sit

h	h	i	m	u	r
r	a	n	u	n	u
p	e	g	g	a	n
a	p	i	g	m	a
t	s	i	t	o	t

Which word matches the picture?

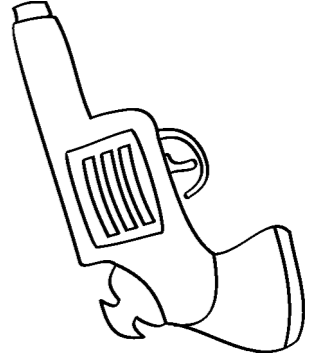

gun  
 jet  
 fun  
 get

# Fun Middle Sound Activities

Name: \_\_\_\_\_

Write the middle sound for each picture.

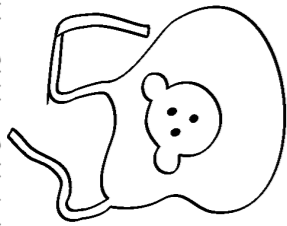

b \_ b

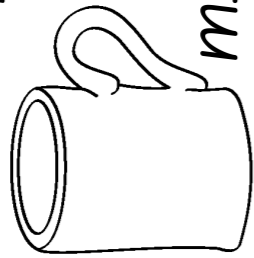

m \_ g

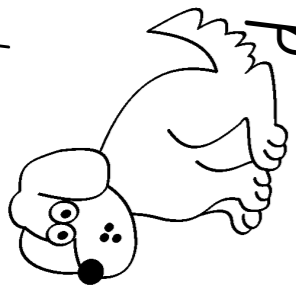

d \_ g



m \_ p

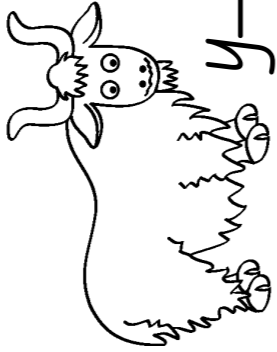

y \_ k

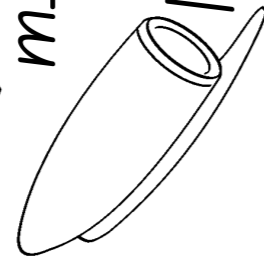

l \_ d

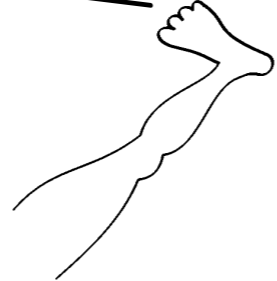

l \_ g

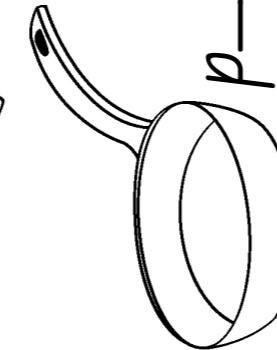

p \_ n

Read and Draw

Here is a red hen.

Match the rhyming words.

fox  
fig  
man  
hop

dig  
van  
box  
mop

# Fun Mixed Exercises: sh

Name: \_\_\_\_\_

Can you find these **sh** words?

~~she~~  
shin  
ship  
shot  
shut  
shy

s	h	i	n	n	s
h	o	s	h	i	p
y	s	h	u	t	s
y	s	e	h	o	t
s	h	o	t	t	s

Which words do not start with **sh** ?

shoe shark shape dish

shell snow show shoot

shot short wish shop

Circle the correct starting sound.

th

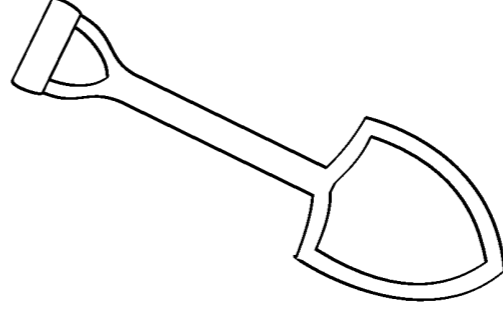

ch

sh

wh

Write the starting sound:

\_\_\_\_\_ark

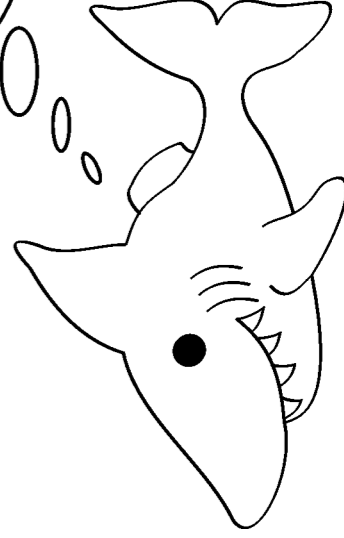

# Fun Mixed Exercises: ch

Name: \_\_\_\_\_

Circle the correct starting sound.

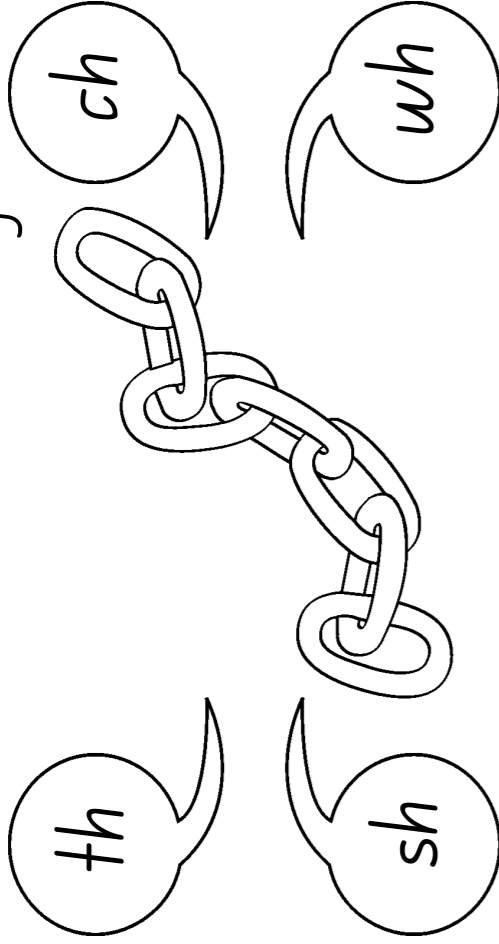

Which words do not start with **ch**?

- chop   chill   chair   witch
- each   chip   cheer   chess
- chew   cheer   chat   patch

Write the starting sounds for these pictures:

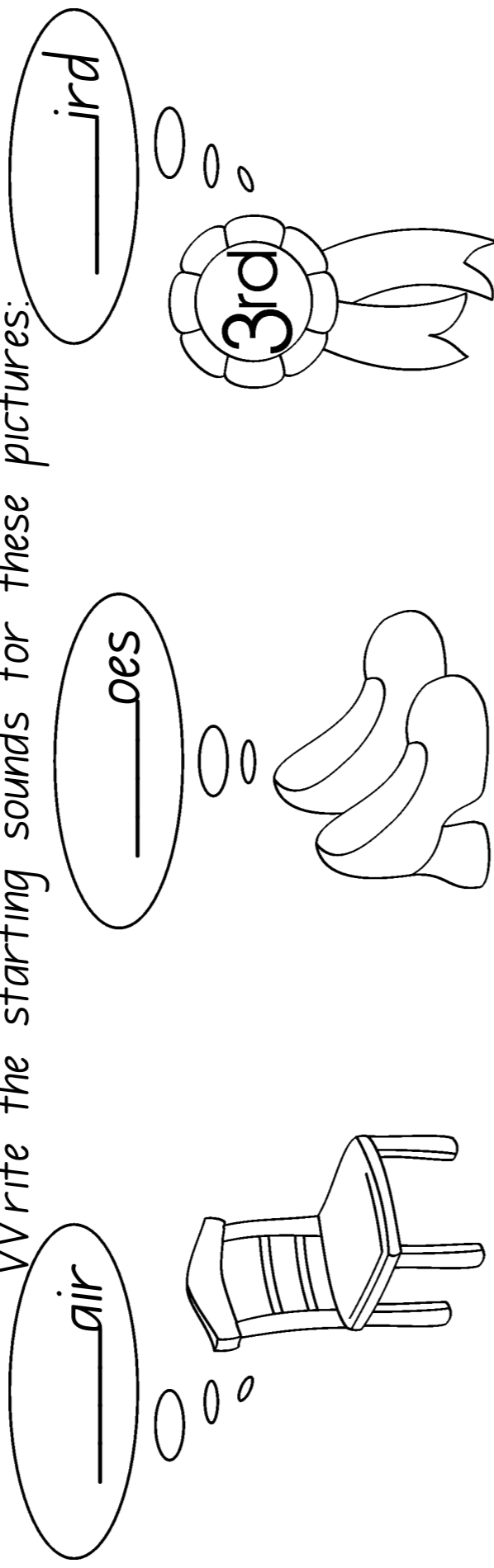

# Fun Middle Sound Activities

Name: \_\_\_\_\_

Write the middle sound for each picture.

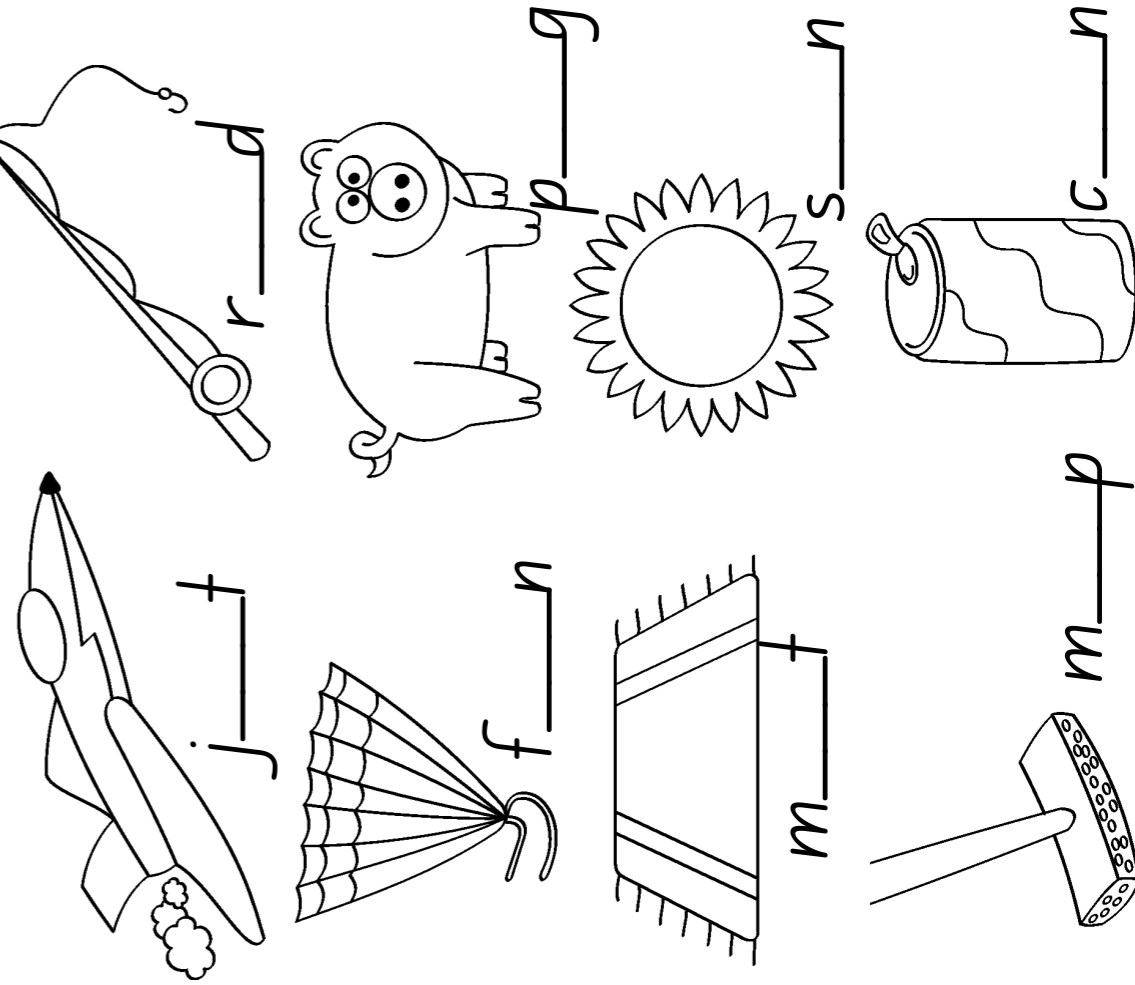

Which words rhyme with the picture?

- 
- tap   cot   cup   lap
  - cog   nap   cat
  - wig   map   sap   pup

Unjumble the words.

- pcu   \_\_\_\_\_
- uth   \_\_\_\_\_
- ffi   \_\_\_\_\_

# Fun Middle Sound Activities

Name: \_\_\_\_\_

Which words rhyme with the picture?

cat      nan  
 pan      peg      cap  
       cot      fan  
 van      pot  
 ran      man      cup

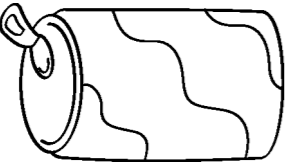

Read and Draw

I can run.

Which word matches the picture?

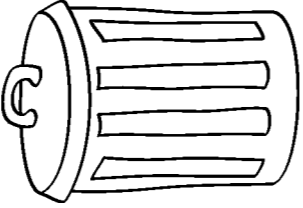
  
 pin  
 big  
 bin  
 bib



Unjumble the words.

wgi \_\_\_\_\_  
 nau \_\_\_\_\_  
 oph \_\_\_\_\_

# Beginning Sounds: th

Name: \_\_\_\_\_

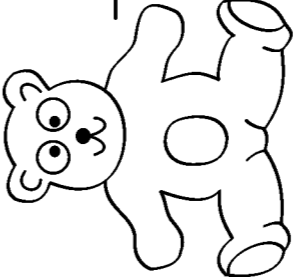
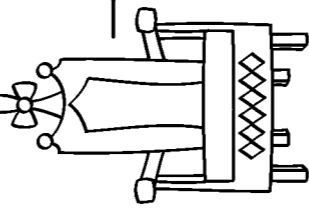
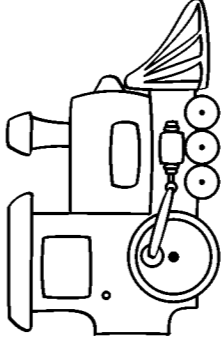
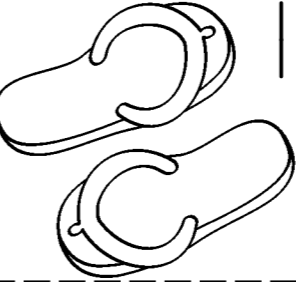
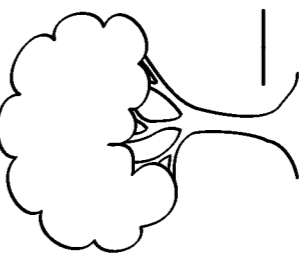
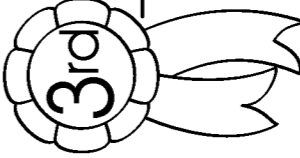
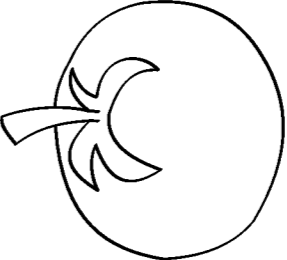
Write the starting sounds for each picture.

Paste the pictures that start with **th** below:

th	th	th	th
----	----	----	----



# Beginning Sounds: wh

Name: \_\_\_\_\_

Write the starting sounds for each picture.

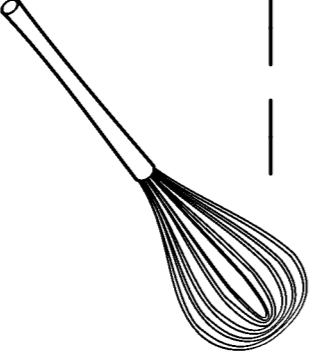
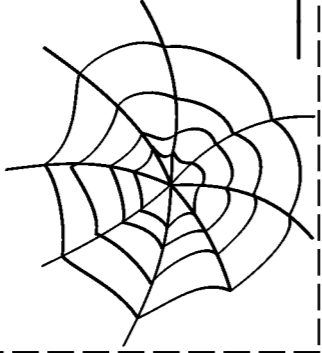
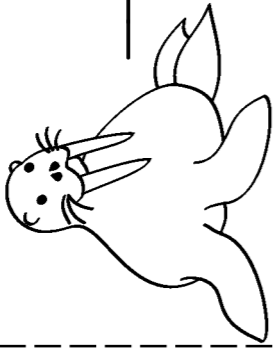
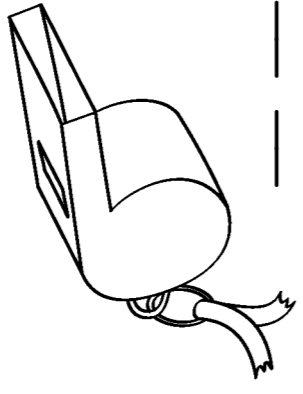
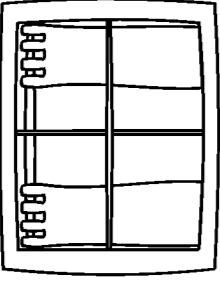
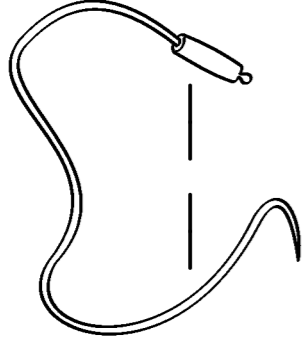
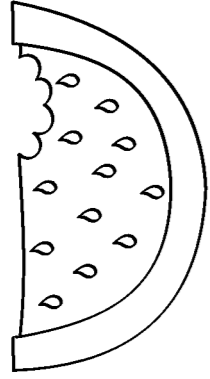
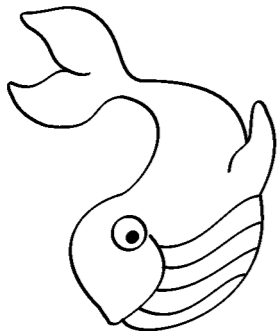

Paste the pictures that start with wh below:

wh

wh

wh

wh

wh

# Fun Middle Sound Activities

Name: \_\_\_\_\_

Colour the pictures with (i)

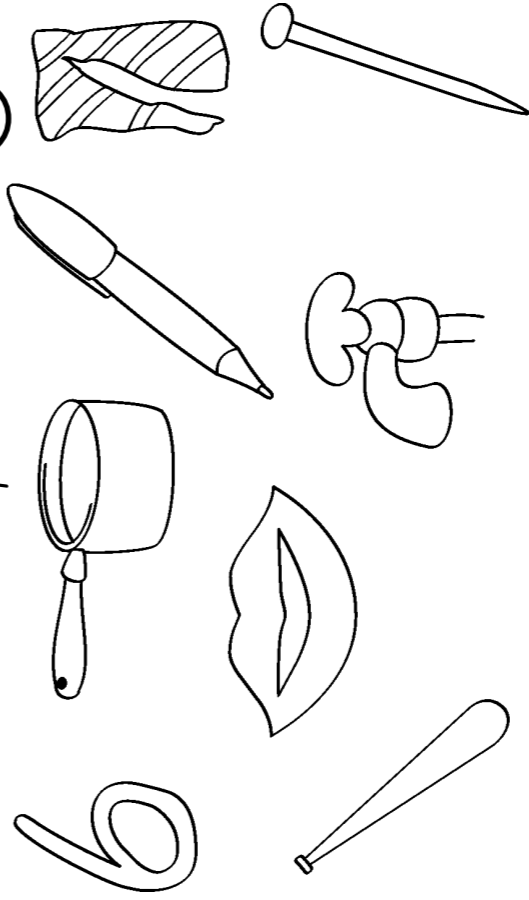

How many words can you find?

\*Find words that have 3 letters\*

p i g b a t  
e d o g r h  
t e b c a e  
a p i b t n  
c a t r a m

Which word matches the picture?

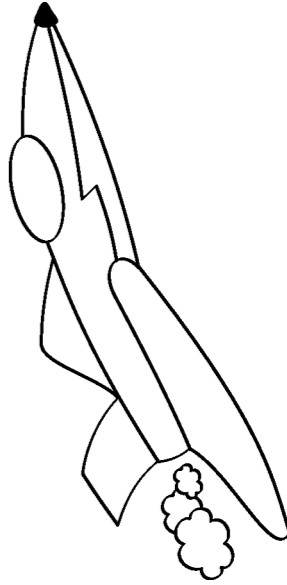

jug  
set  
bet  
jet

Match the rhyming words.

not  
rag  
rat  
hip

sat  
sip  
pot  
tag

# Fun Middle Sound Activities

Name: \_\_\_\_\_

Unjumble the words.

wgi \_\_\_\_\_

nav \_\_\_\_\_

oph \_\_\_\_\_

Can you find these words?

~~bug~~

cog

fig

hat

pup

web

w	e	b	n	a	n
i	g	u	a	a	b
c	o	g	f	s	i
r	e	p	u	p	u
f	i	g	d	i	r

Which words rhyme with the picture?

rat

bib

fat

mat

hat

cot

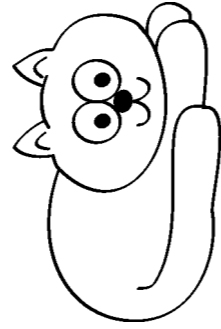

lip

sat

pat

pup

bat

cup

Read and Draw

I can see a big pig.

# Beginning Sounds: sh

Name: \_\_\_\_\_

Write the starting sounds for each picture.

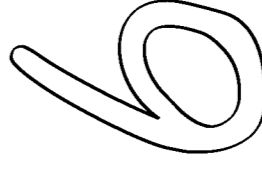
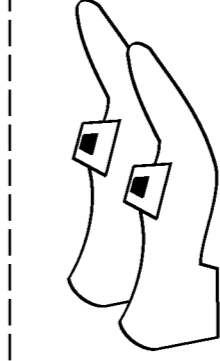
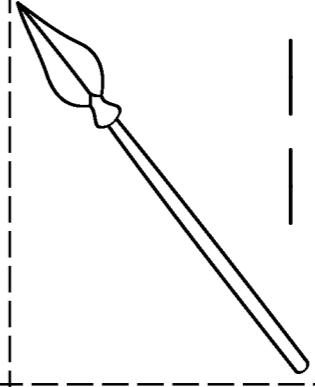
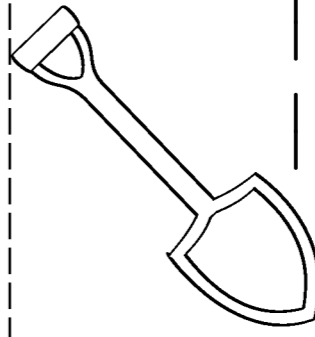
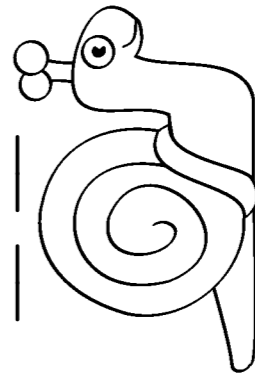
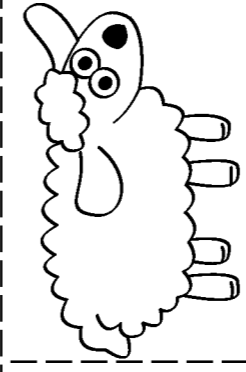
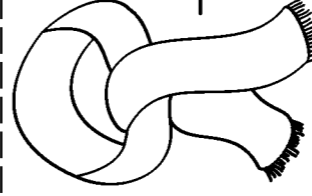
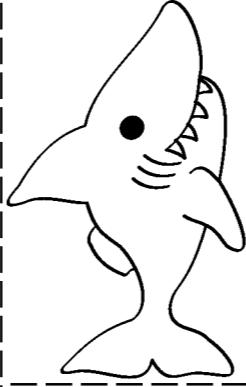
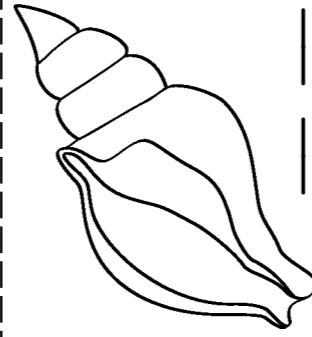
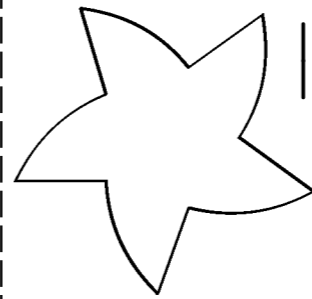

Paste the pictures that start with **sh** below:

sh

sh

sh

sh

sh

# Beginning Sounds: ch

Name: \_\_\_\_\_

Write the starting sounds for each picture.

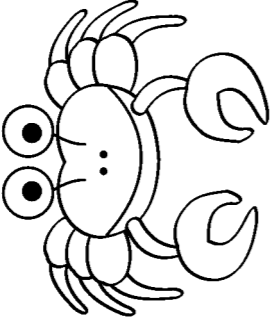
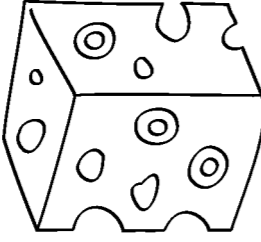
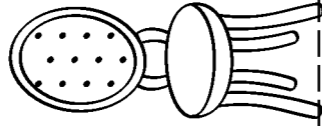
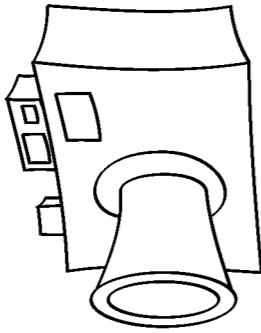
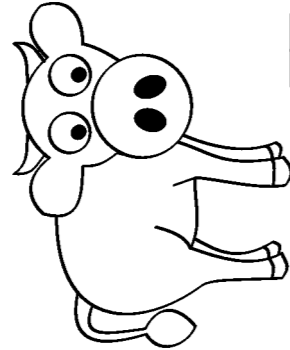
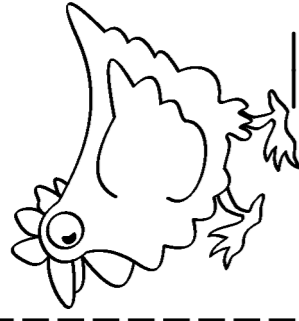
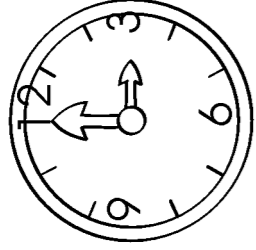
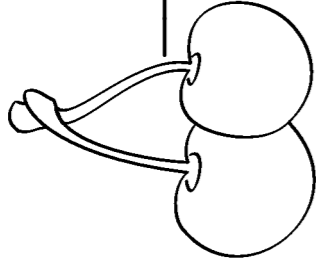
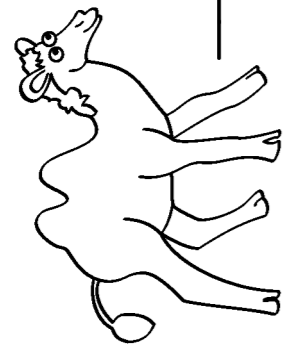
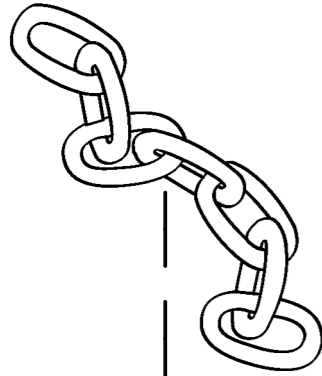

Paste the pictures that start with **ch** below:

ch	ch	ch	ch
----	----	----	----

# Fun Middle Sound Activities

Name: \_\_\_\_\_

Colour the pictures with **o**.

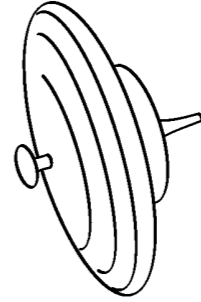
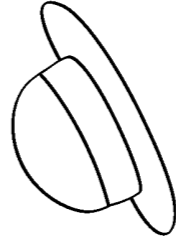
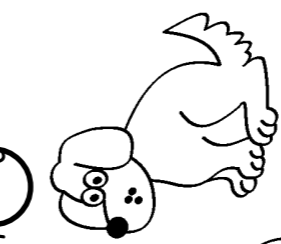
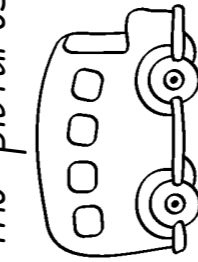

I can see a fat cat.

Which word matches the picture?

6

six

mix

set

sit

leg

fog

pit

mad

Match the rhyming words.

bit

jog

bad

beg

# Fun Middle Sound Activities

Name: \_\_\_\_\_

Unjumble the words.

ppi \_\_\_\_\_

bti \_\_\_\_\_

nfi \_\_\_\_\_

Which word matches the picture?

hot

hit

hat

hut

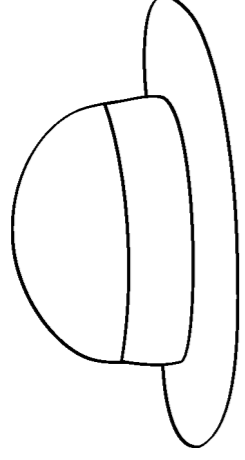

True or False?

t r u e

f a l s e

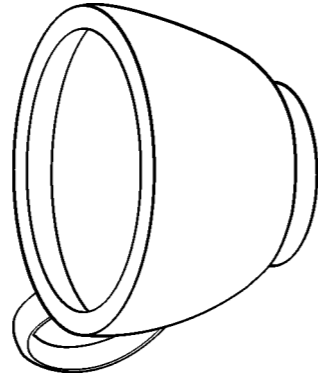

This is a big cat.

Read and Draw

I can see a red mat.

# Beginning Sounds: tr

Name: \_\_\_\_\_

Write the starting sounds for each picture.

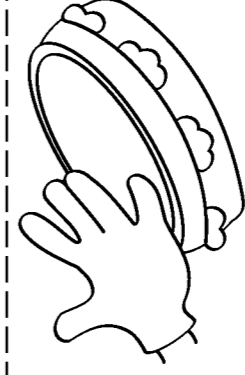
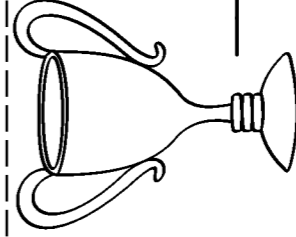
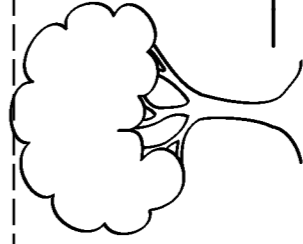
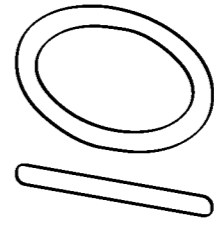
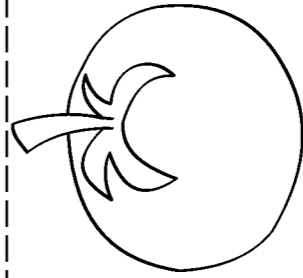
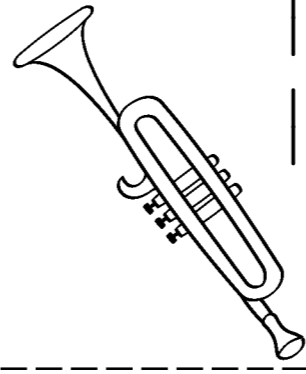
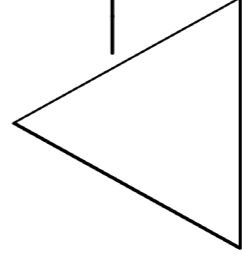
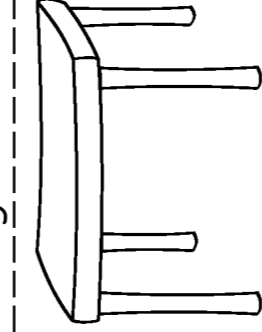
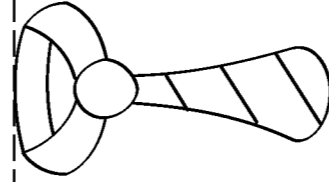
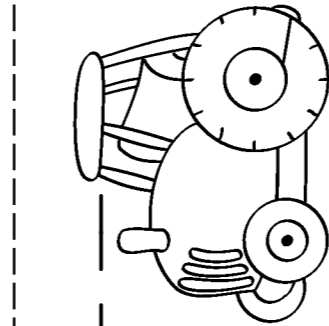

Paste the pictures that start with **tr** below:

tr

tr

tr

tr

tr

# Beginning Sounds: st

Name: \_\_\_\_\_

Write the starting sounds for each picture.

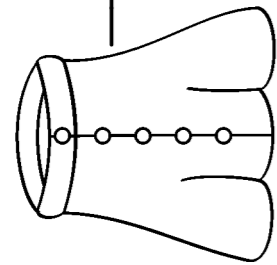

\_\_\_\_\_

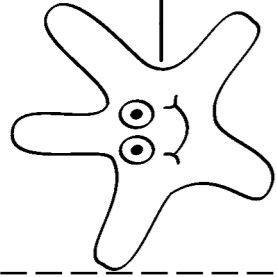

\_\_\_\_\_



\_\_\_\_\_

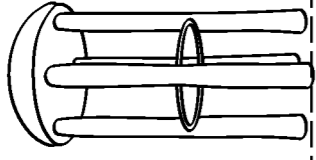

\_\_\_\_\_

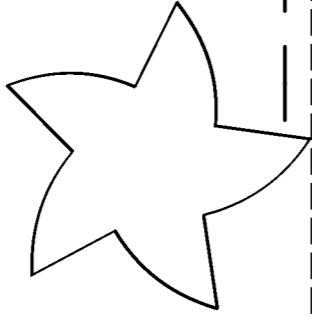
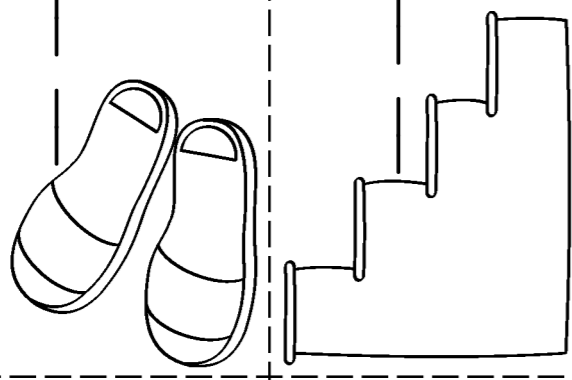

\_\_\_\_\_

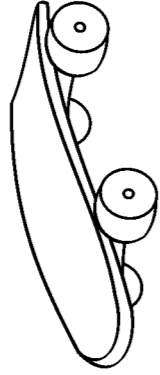

\_\_\_\_\_

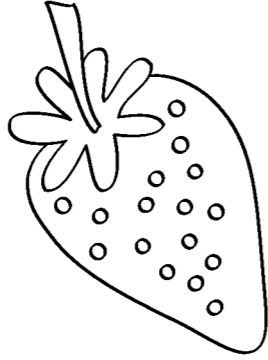

\_\_\_\_\_

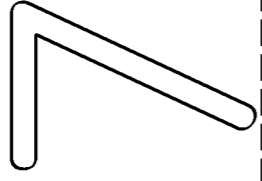

\_\_\_\_\_

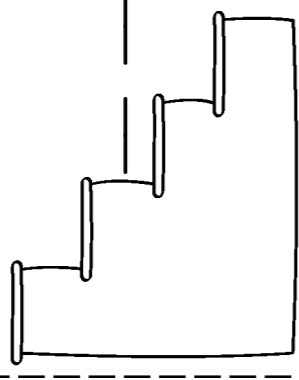

Paste the pictures that start with **st** below:

st

st

st

st

st

# Fun Middle Sound Activities

Name: \_\_\_\_\_

True or False?

t r u e

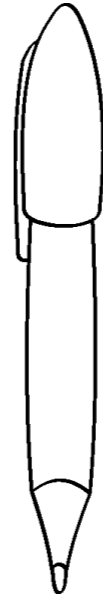

This is a big pin.

Read and Draw

Here is a big red dot.

Which word matches the picture?

- tip
- top
- tap
- tub

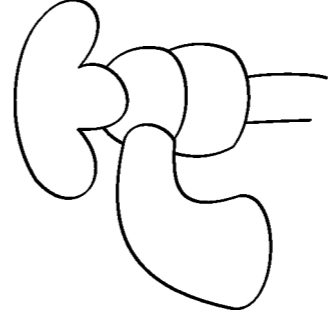

\_\_\_\_\_

Match the rhyming words.

- |     |     |
|-----|-----|
| big | bed |
| ted | met |
| pet | pig |
| pot | dot |

# Fun Middle Sound Activities

Name: \_\_\_\_\_

Read and Draw

Here is a cricket bat.

Which word matches the picture?

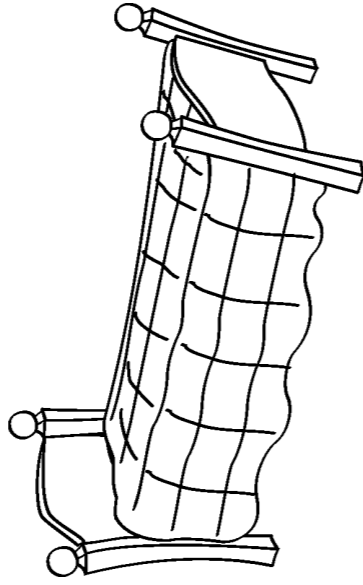

- bed
- bib
- bad
- dad

\_\_\_\_\_

Circle the word that does not rhyme.

wet    vet    got    pet

fat    hit    mat    hat

cog    dog    big    jog

True or False?

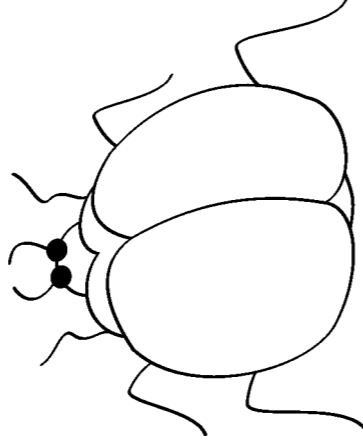

This is a bug.

t    r    u    e

f    a    l    s    e

# Beginning Sounds: sp

Name: \_\_\_\_\_

Write the starting sounds for each picture.

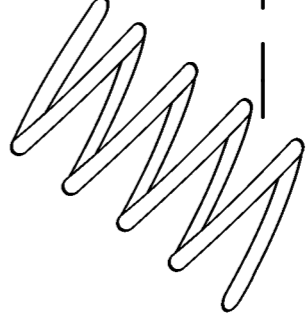
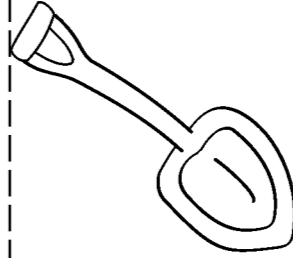
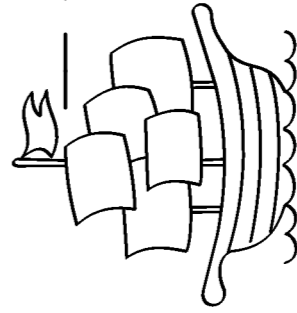
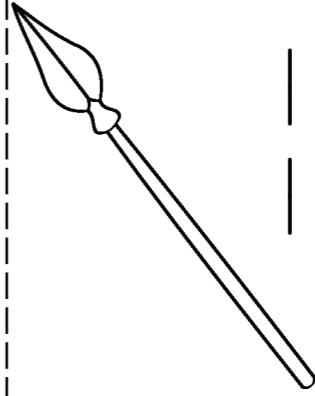
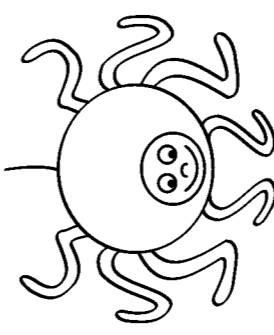
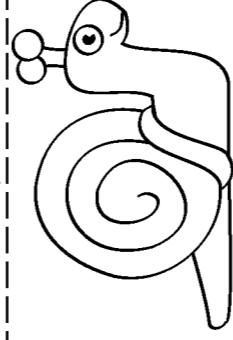
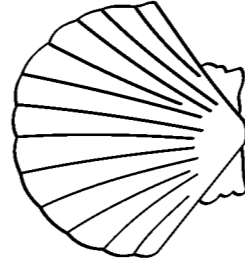
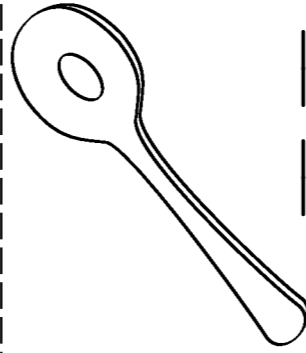
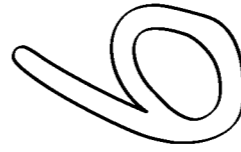

Paste the pictures that start with **sp** below:

sp

ds

sp

ds

sp

# Beginning Sounds: pl

Name: \_\_\_\_\_

Write the starting sounds for each picture.

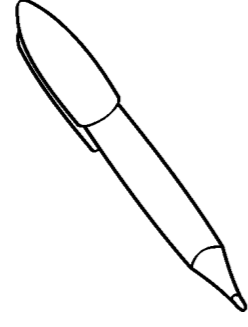
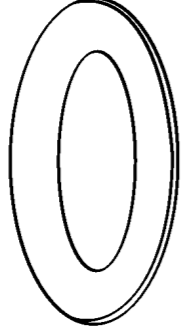
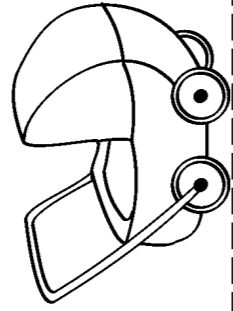
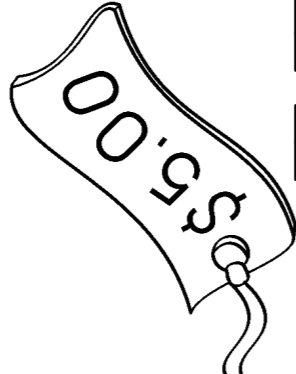
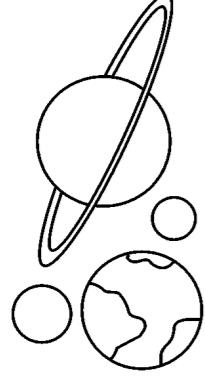
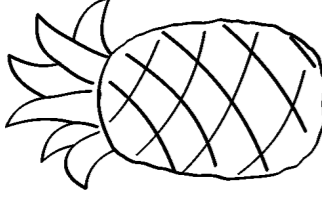
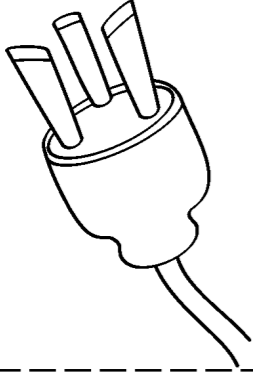
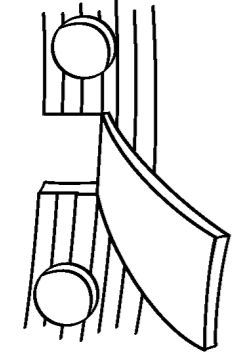
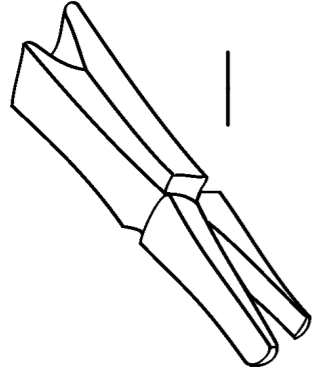

Paste the pictures that start with **pl** below:

pl	pl	pl	pl	pl
----	----	----	----	----

# Fun Middle Sound Activities

Name: \_\_\_\_\_

Match the words to the pictures.



--	--	--



--	--	--

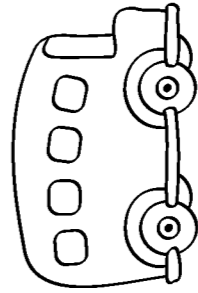

--	--	--

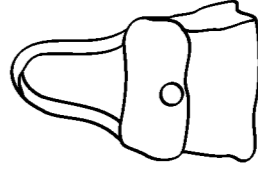

--	--	--

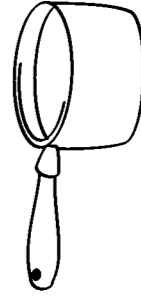

--	--	--

bus pot fin net bag

Unjumble the words.

bbi

ebw

mra

Which words rhyme with the picture?

mug bag

rug bit

jug

did

dig

dip



hug

big

# Fun Middle Sound Activities

Name: \_\_\_\_\_

Match the words to the pictures.

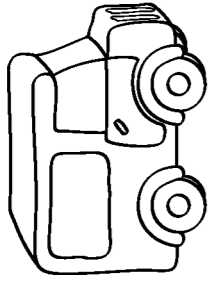

--	--	--

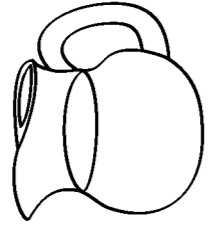

--	--	--



--	--	--



--	--	--

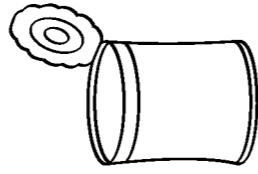

--	--	--

hen van jug tin map

Unjumble the words.

sti \_\_\_\_\_

gwi \_\_\_\_\_

xfo \_\_\_\_\_

Which words rhyme with **pet** ?

m	e	t	t	e	b
s	e	t	l	j	e
c	e	n	g	e	t
r	w	e	t	e	
z	e	t	v	e	t

# Beginning Sounds: gl

Name: \_\_\_\_\_

Write the starting sounds for each picture.

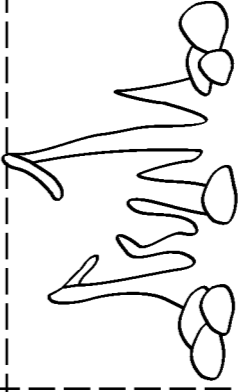
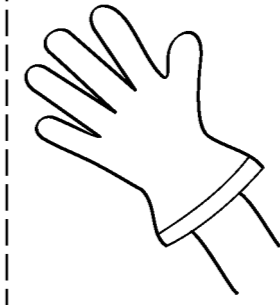
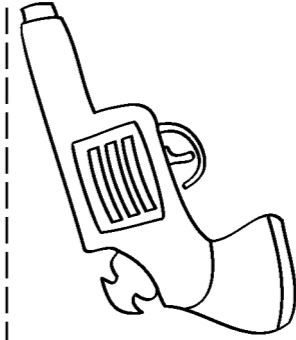
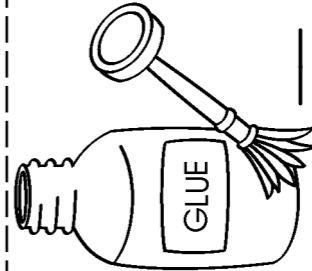
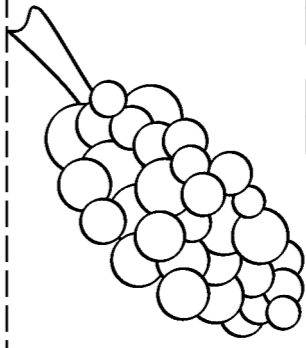
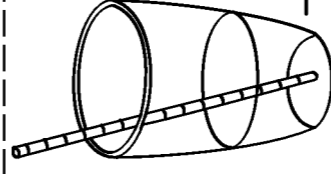
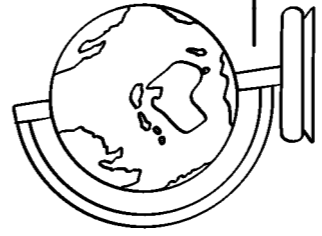
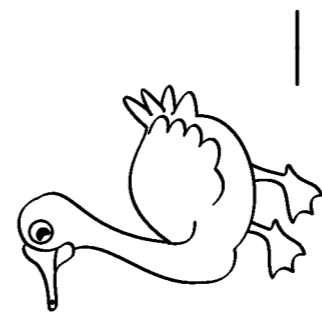
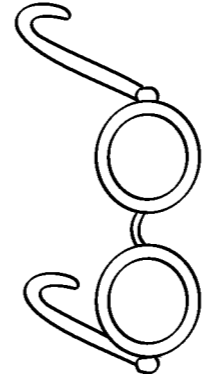

Paste the pictures that start with **gl** below:

gl

gl

gl

gl

gl



# Beginning Sounds: cl

Name: \_\_\_\_\_

Write the starting sounds for each picture.

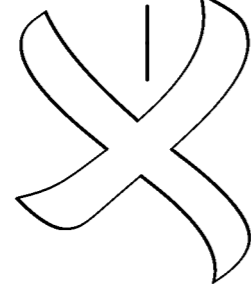
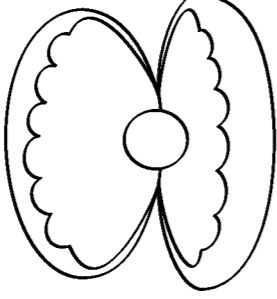
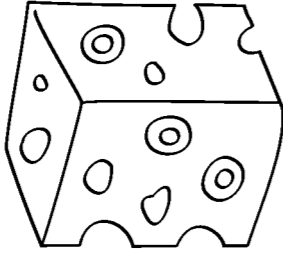
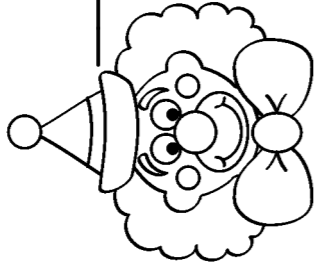
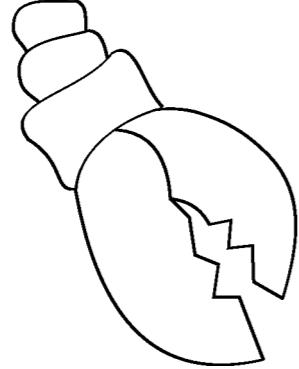
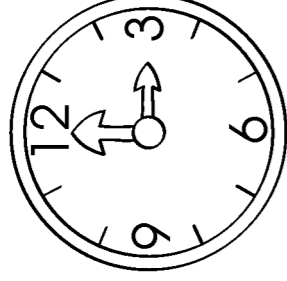
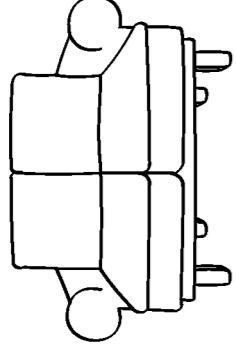
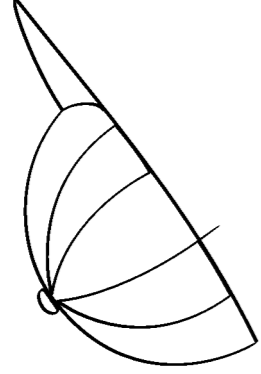
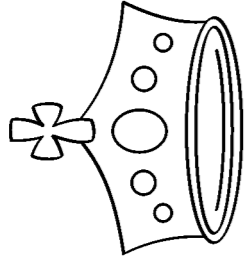
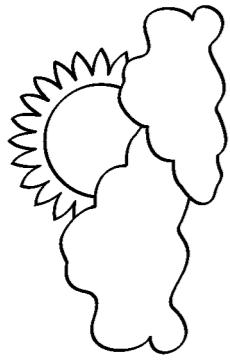

Paste the pictures that start with **cl** below:

cl	cl	cl	cl	cl
----	----	----	----	----

# Fun Middle Sound Activities

Name: \_\_\_\_\_

Match the words to the pictures.

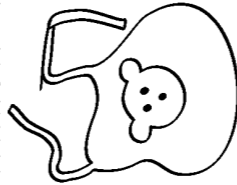

--	--	--

--	--	--



--	--	--

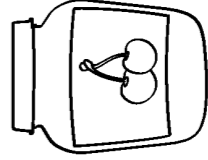
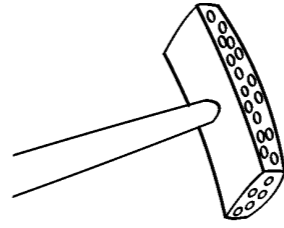

--	--	--

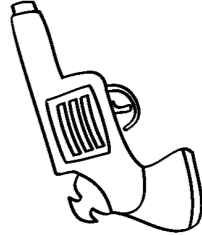

--	--	--

jam mop gun web bib

Unjumble the words.

pto

nep

sta

Which words rhyme with **zip** ?

p	i	t	r	i	p
a	i	b	u	s	
h	i	p	g	n	i
i	p	i	p	i	p
s	b	i	t	p	p

# Fun Middle Sound Activities

Name: \_\_\_\_\_

Which words have **a** as the middle sound?

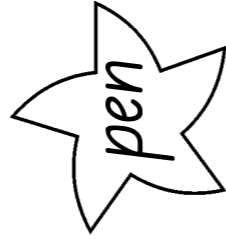
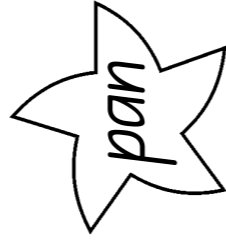
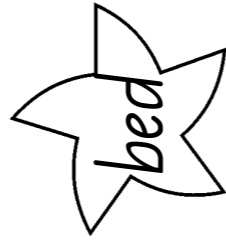
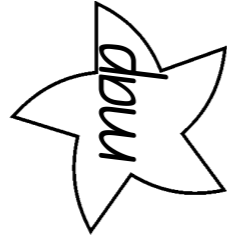
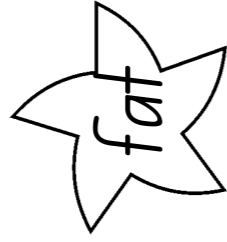
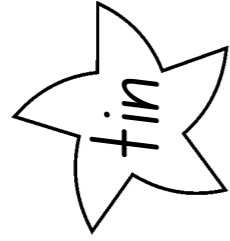
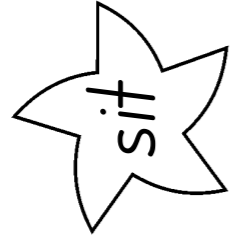
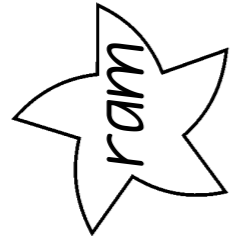
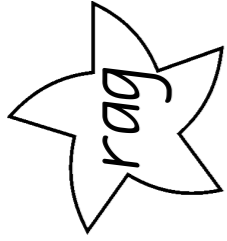
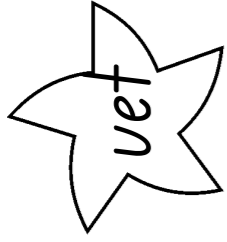
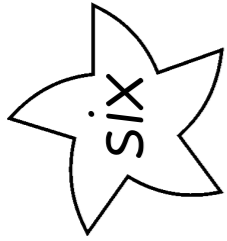

Unjumble the words.

ddi \_\_\_\_\_

dor \_\_\_\_\_

nma \_\_\_\_\_

Which words rhyme with **can** ?

f	a	n	i	b	u
m	o	p	r	a	a
a	i	t	a	n	n
n	p	a	n	i	a
d	a	n	a	n	p

# Beginning Sounds: bl

Name: \_\_\_\_\_

Write the starting sounds for each picture.

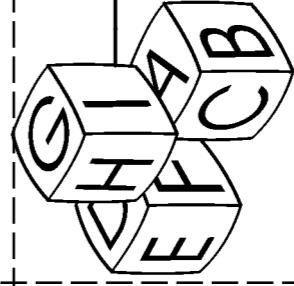
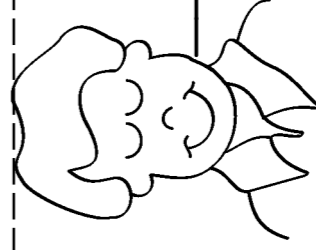
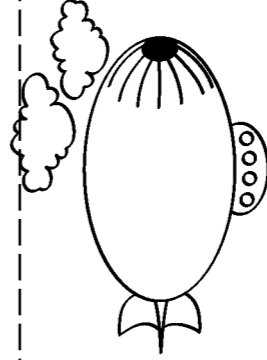
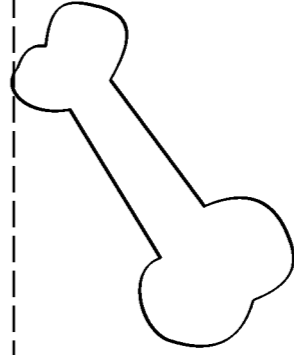
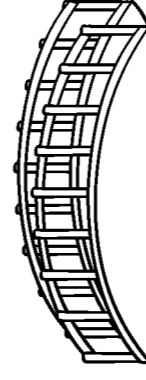
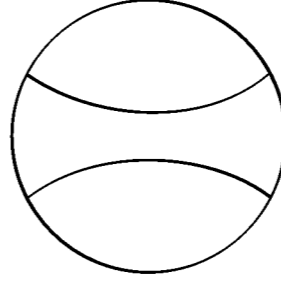
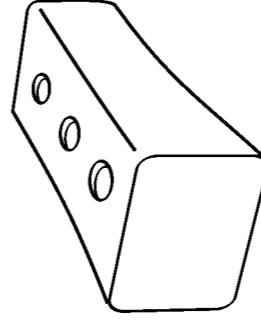
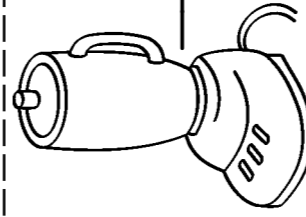
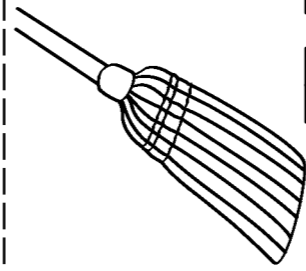

Paste the pictures that start with **bl** below:

bl

bl

bl

bl

bl

# Fun Middle Sound Activities

Name: \_\_\_\_\_

Which words have **u** as the middle sound?

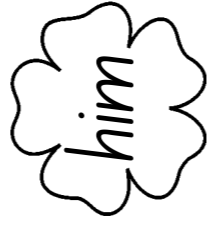
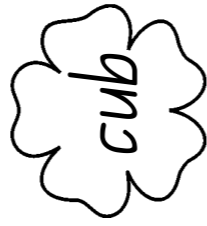
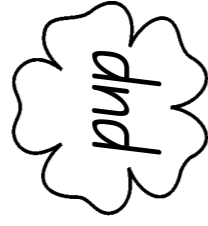
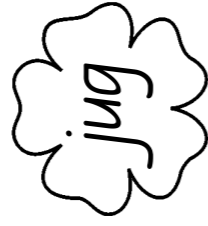
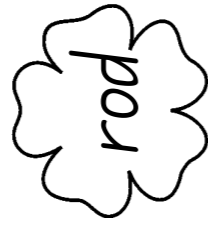
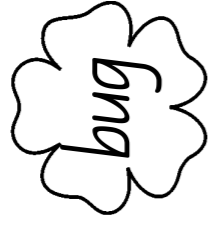
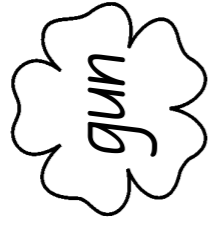
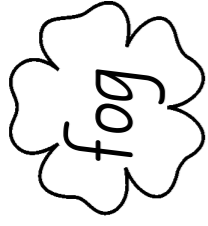
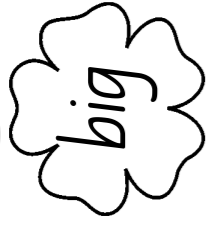
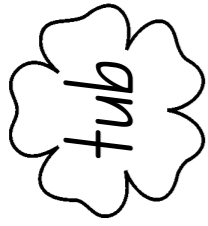

Choose letters to make **at** words.

~~z~~ h f g b r n m

~~cat~~    at    at

at    at

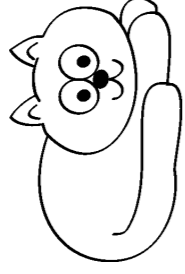

Read and Draw

I can see a brown rat.

# Fun Middle Sound Activities

Name: \_\_\_\_\_

Which words have **e** as the middle sound?

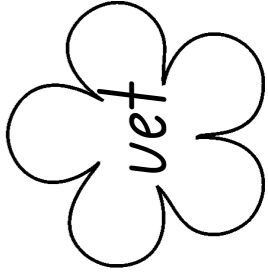
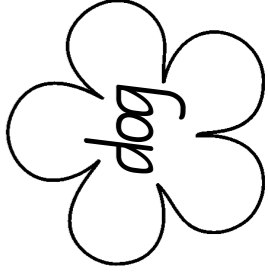
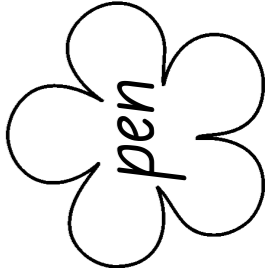
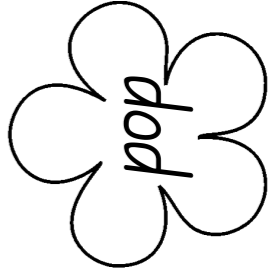
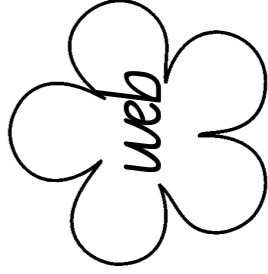
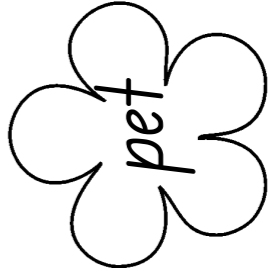
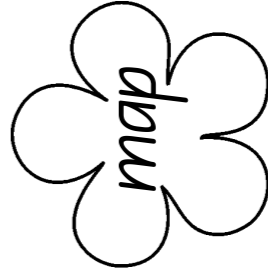
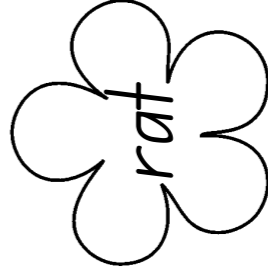
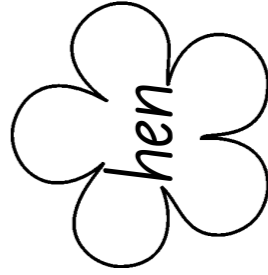
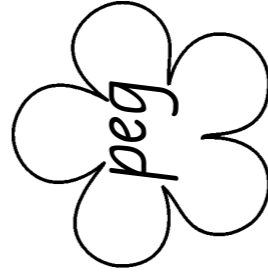
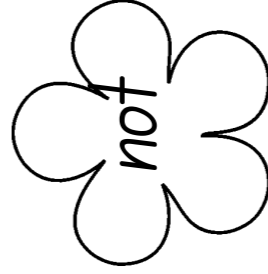
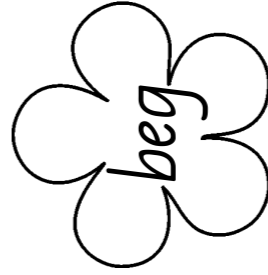

Choose letters to make **ug** words.

~~w~~ r h d f b j y

~~rug~~    ug    ug

ug    ug

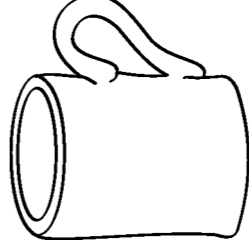

Read and Draw

Here is a bug on a leaf.

# Fun Middle Sound Activities

Name: \_\_\_\_\_

Which words have **(i)** as the middle sound?

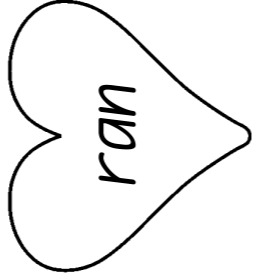
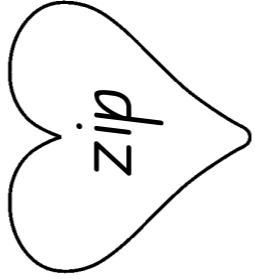
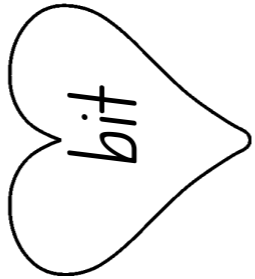
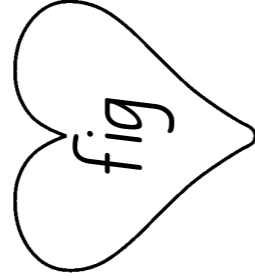
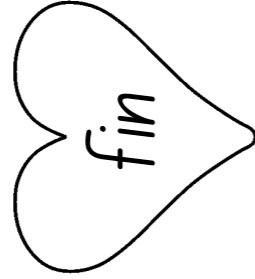
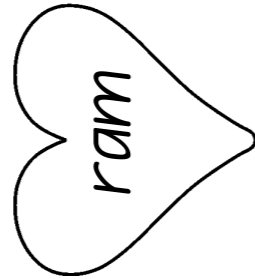
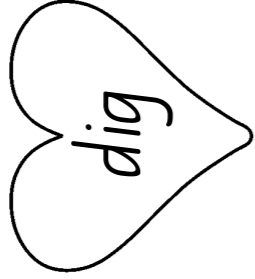
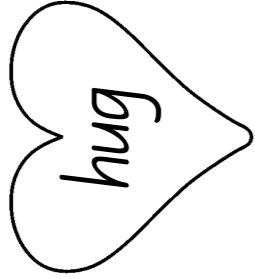
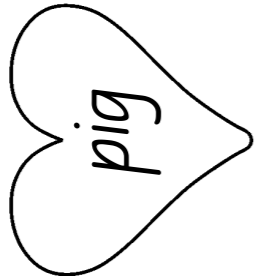
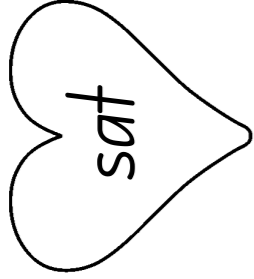
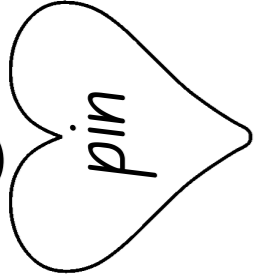
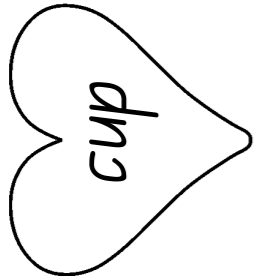

Choose letters to make **(an)** words.

~~w~~ f m l p s r u

can

\_\_an

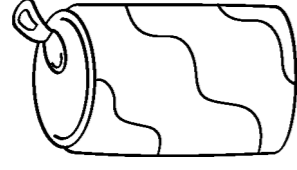

\_\_an

\_\_an

Read and Draw

Here is a green van.

# Fun Middle Sound Activities

Name: \_\_\_\_\_

Which words have **(i)** as the middle sound?

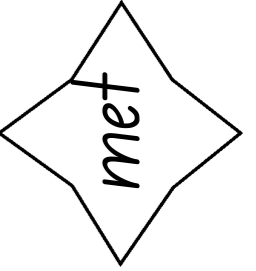
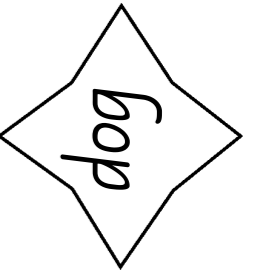
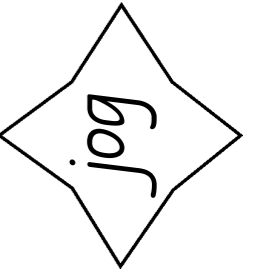
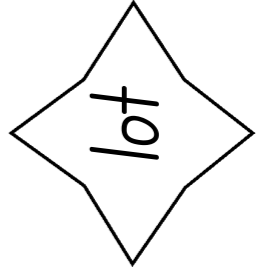
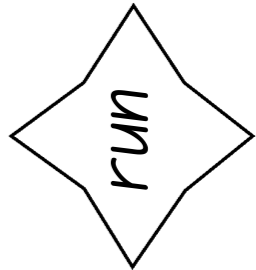
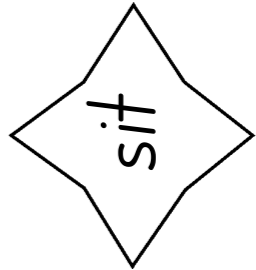
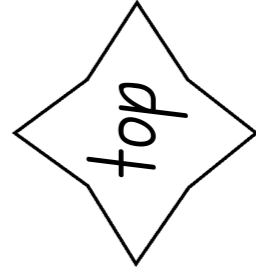
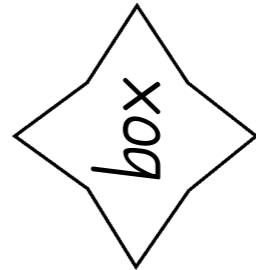
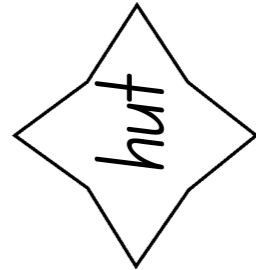
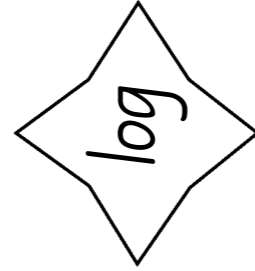
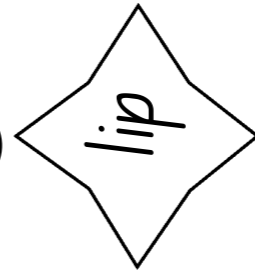
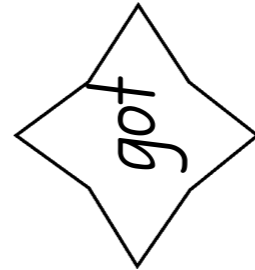

Choose letters to make **(ot)** words.

~~p~~ d w l g c u h z

p~~o~~t

\_\_ot

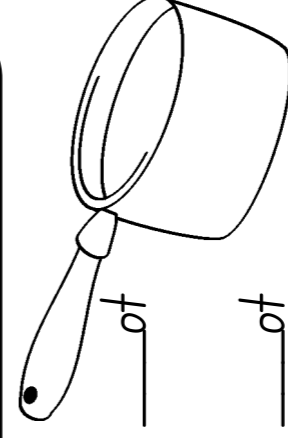

\_\_ot

\_\_ot

Read and Draw

Here is a big black dog.