



For Years 1-3



Alphabet Activities

Book 3 Sound and Word Building

Written by Kerry Heathcote & Kathryn Bryce. © Ready-Ed Publications - 2006.
Published by Ready-Ed Publications (2006) P.O. Box 276 Greenwood Perth W.A. 6024
Email: info@readyed.com.au Website: www.readyed.com.au

COPYRIGHT NOTICE

Permission is granted for the purchaser to photocopy sufficient copies for non-commercial educational purposes. However, this permission is not transferable and applies only to the purchasing individual or institution.

ISBN 1 86397 659 0

Rationale

Sound and Word Building is the third in a four part series called *Alphabet Activities*. It is for use in an early literacy program. This third book provides teachers with a practical series of activity-based worksheets which expand the body of work set out in *Initial Sounds* and *Sound Jigsaws and Word Matching*. The worksheets provide children with the opportunity to identify sounds through a variety of exercises such as cut-and-paste, read and draw, true and false, matching words to pictures and labelling. These activities foster, encourage and reinforce sound recognition, letter formation, letter-sound relationships and fine motor skills. They have been designed to motivate students to develop and learn.

About the Authors

Kerry Heathcote has 36 years teaching experience in Early Childhood in Queensland, New South Wales and Victoria.

Kathryn Bryce is a graphic designer with a Bachelor of Arts (Hons.) degree majoring in Communications. She has worked as a tutor with both children and adults with learning disabilities.

Curriculum Links - Links to Achievement Objectives

English - Level 1

Reading

Personal Reading - Students will begin to use semantic, syntactic, visual, and grapho-phonetic cues to gain meaning.

Close Reading - Students will respond to language and meanings in texts.

Reading Processes

Exploring Language - Students will explore choices made by writers, and identify and use the common conventions of writing and organisation of text which affect understanding.

Fun with Labelling

Name: _____

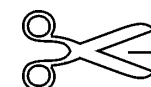
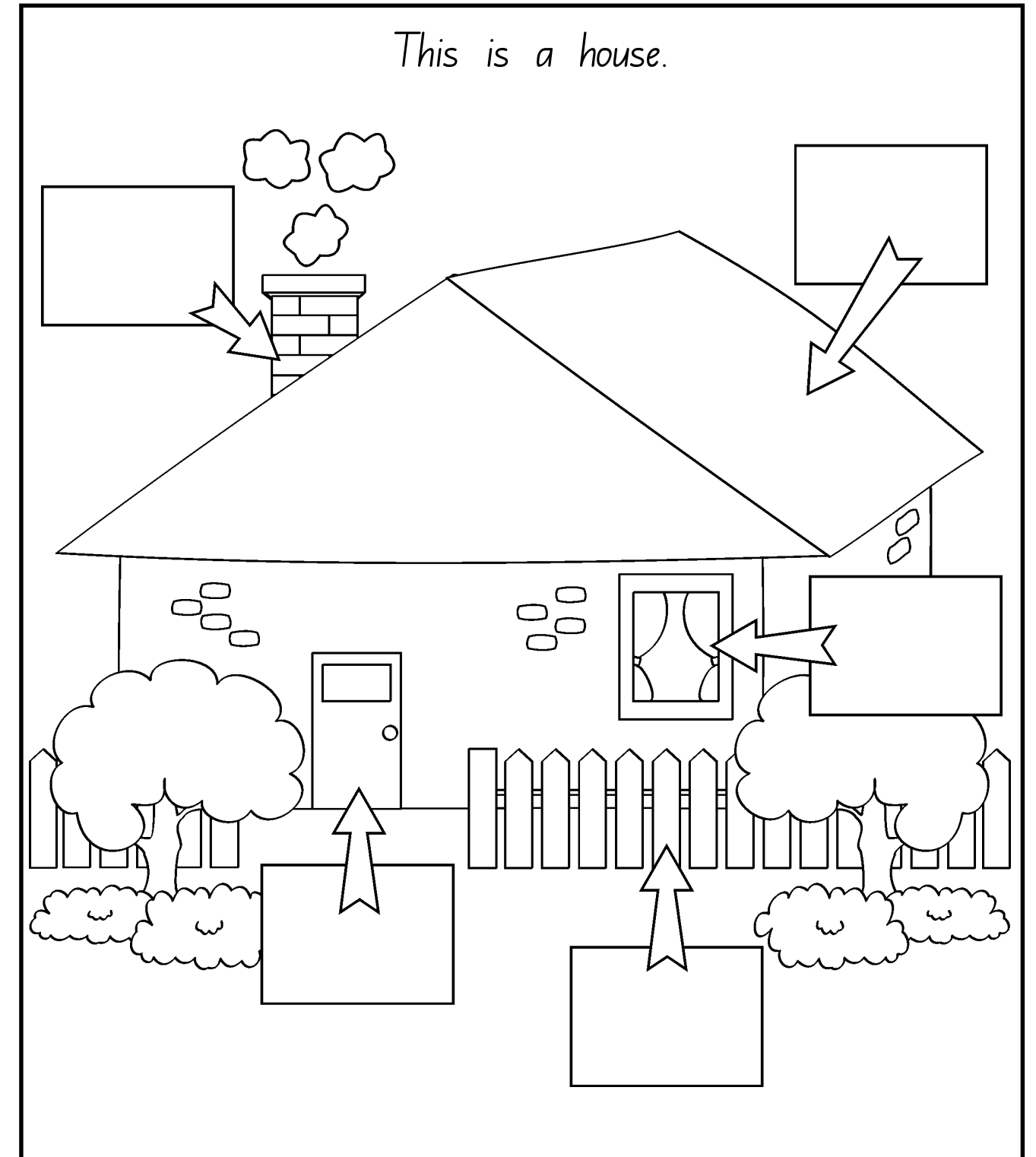

Cut and paste the words into their correct place.

fence chimney roof door window

Fun with Labelling

Name: _____

These are my toys.

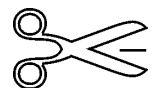
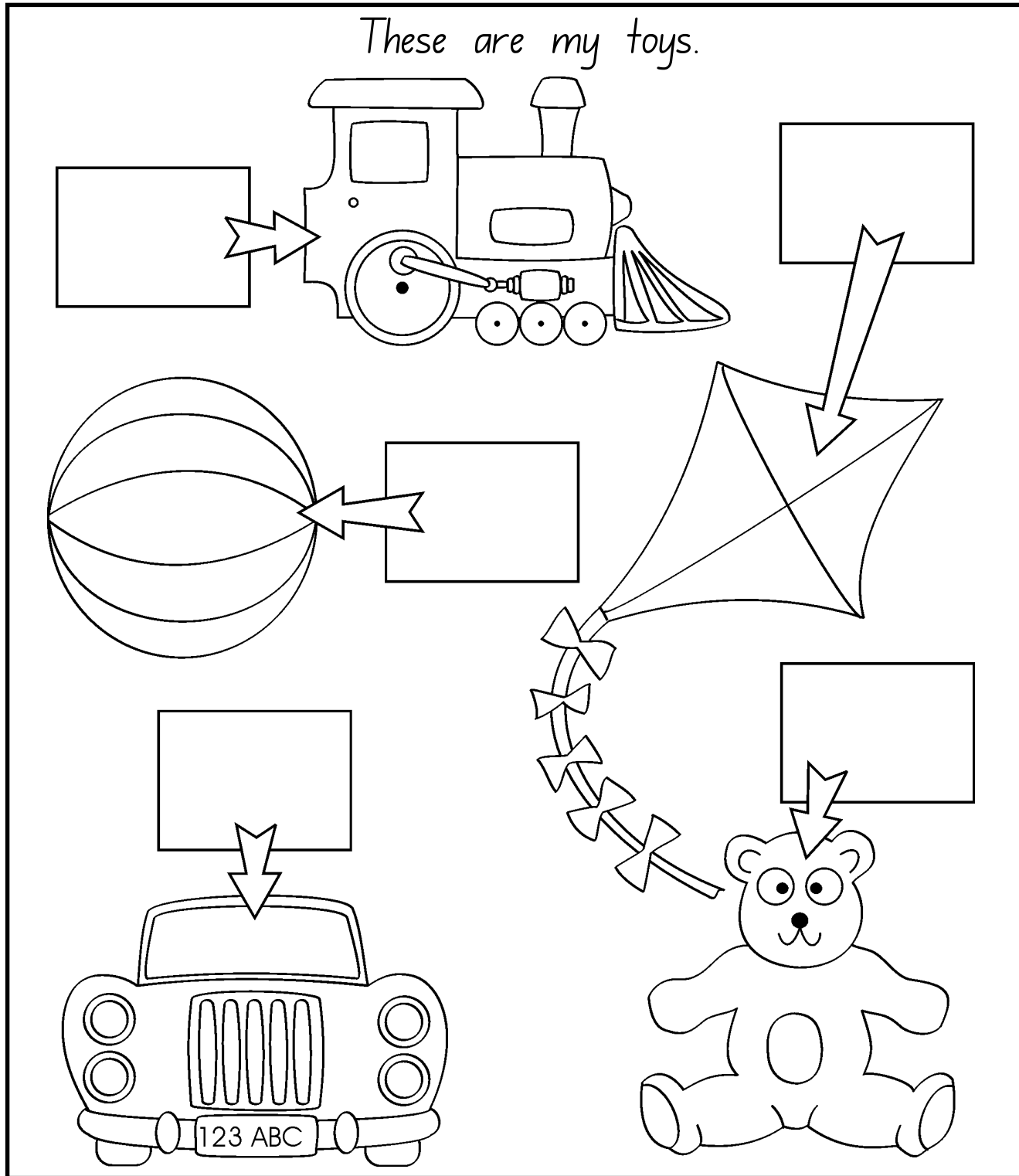

Cut and paste the words into their correct place.

teddy	train	kite	ball	car
-------	-------	------	------	-----

Contents

Fun With Starting Sounds..... pages 4–19

Circle the Initial Sound

Write the Initial Sound

Match the Initial Sound

Fun With Starting Sounds and Drawing pages 20–26

Read and Draw

Write the Initial Sound

Fun With Starting Sounds and Words..... pages 27–32

Write the Initial Sound

Read and Draw

Identify the Correct Sound

Identify the Correct Word

Fun With Starting Sounds and Sentences pages 33–40

Match the Word to the Picture

Identify the Correct Sound

Read and Draw

True or False

Fun With Labelling

Label the Pets page 41

Label the Farm Animals page 42

Label the Zoo Animals page 43

Label the Sea Animals page 44

Label the Clothes page 45

Label the Vehicles page 46

Label the Food page 47

Label the Boy page 48

Label the Girl page 49

Label the Face page 50

Label the Dog page 51

Label the Hen page 52

Label the Fish page 53

Label the Toys page 54

Label the House page 55

Fun With Starting Sounds

Name: _____

Circle the correct starting sounds.

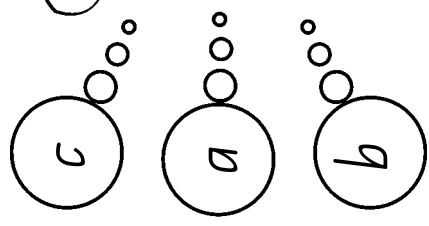
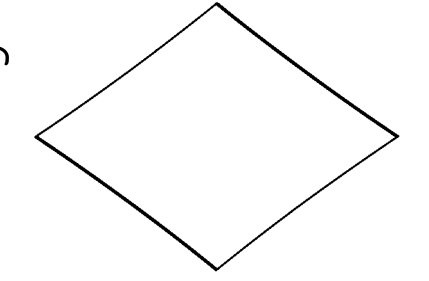
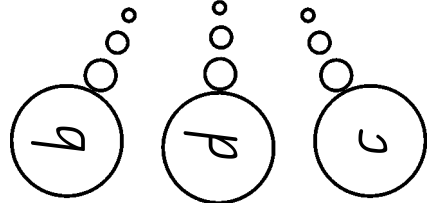
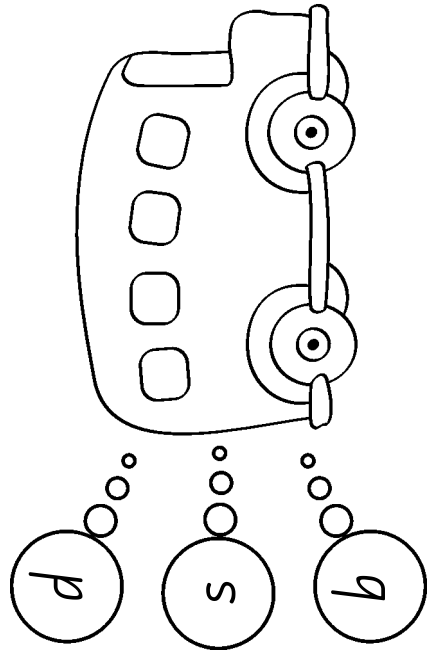

Write the starting sounds.

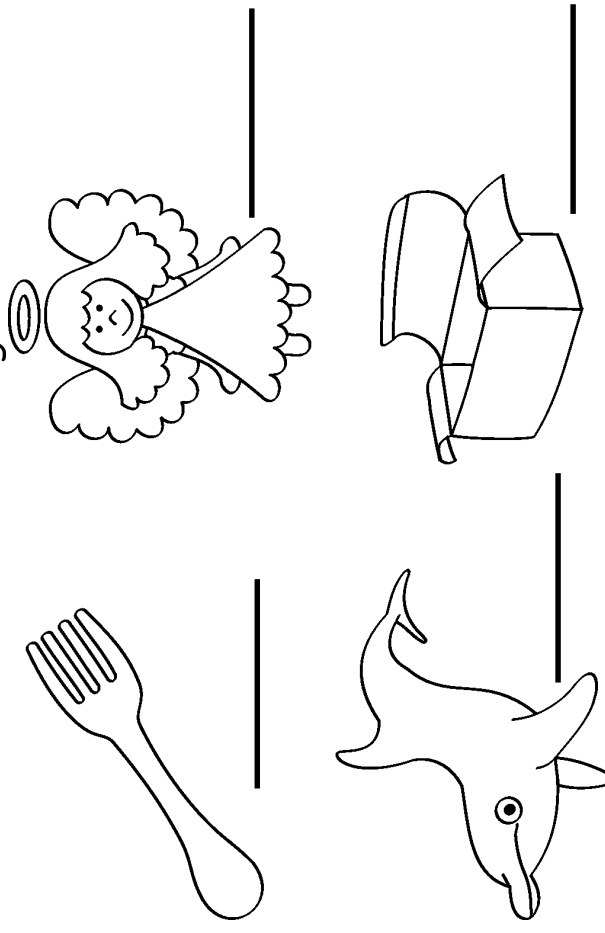

Which sound matches the picture?



Fun with Labelling

Name: _____

This is a fish.

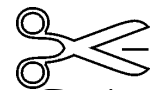
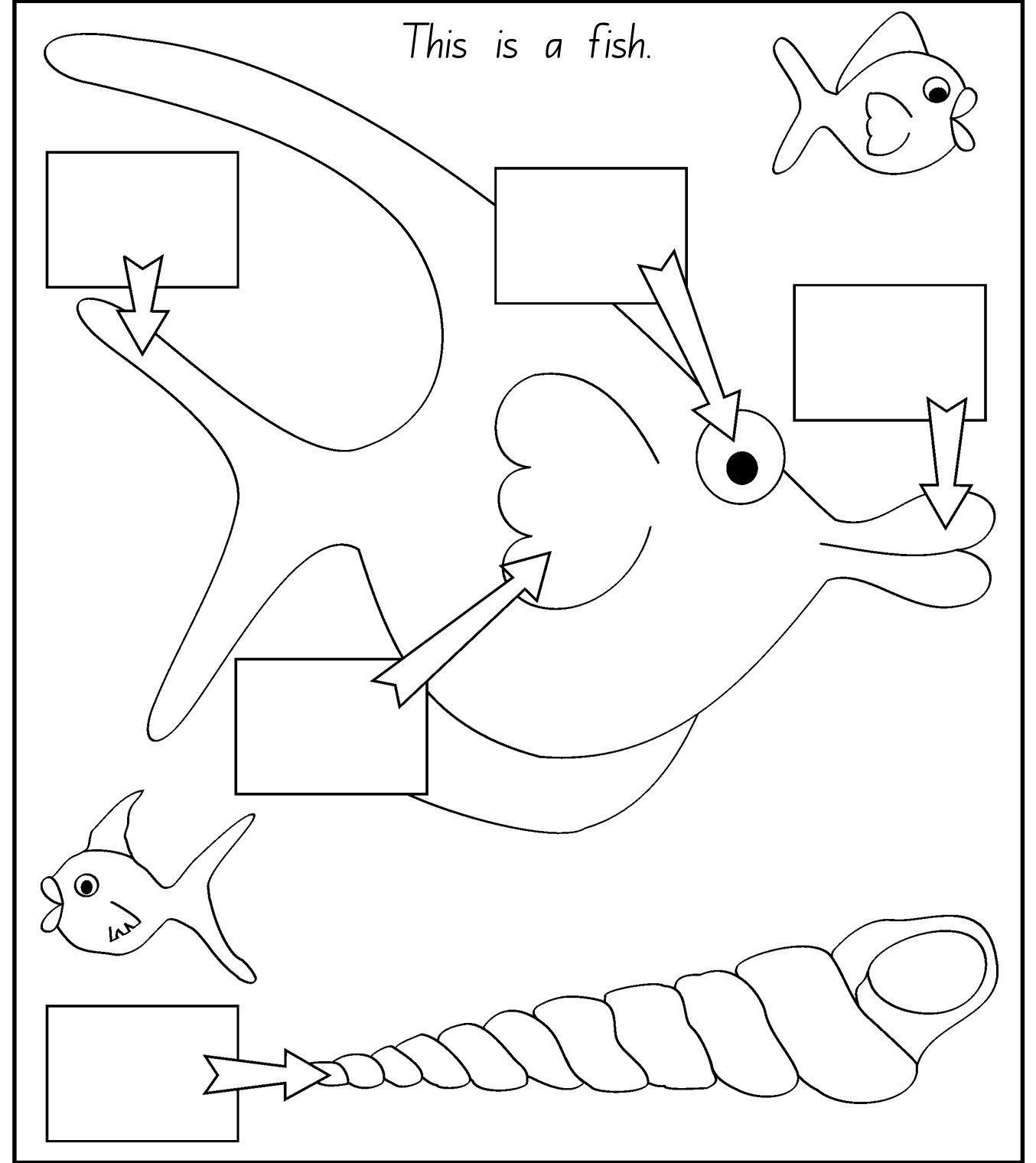

Cut and paste the words into their correct place.

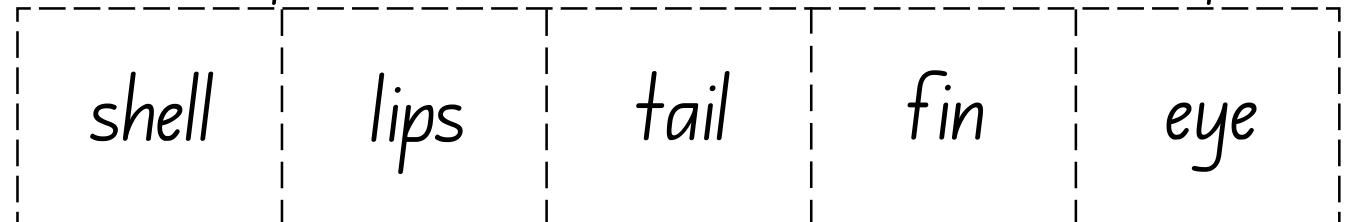

Fun with Labelling

Name: _____

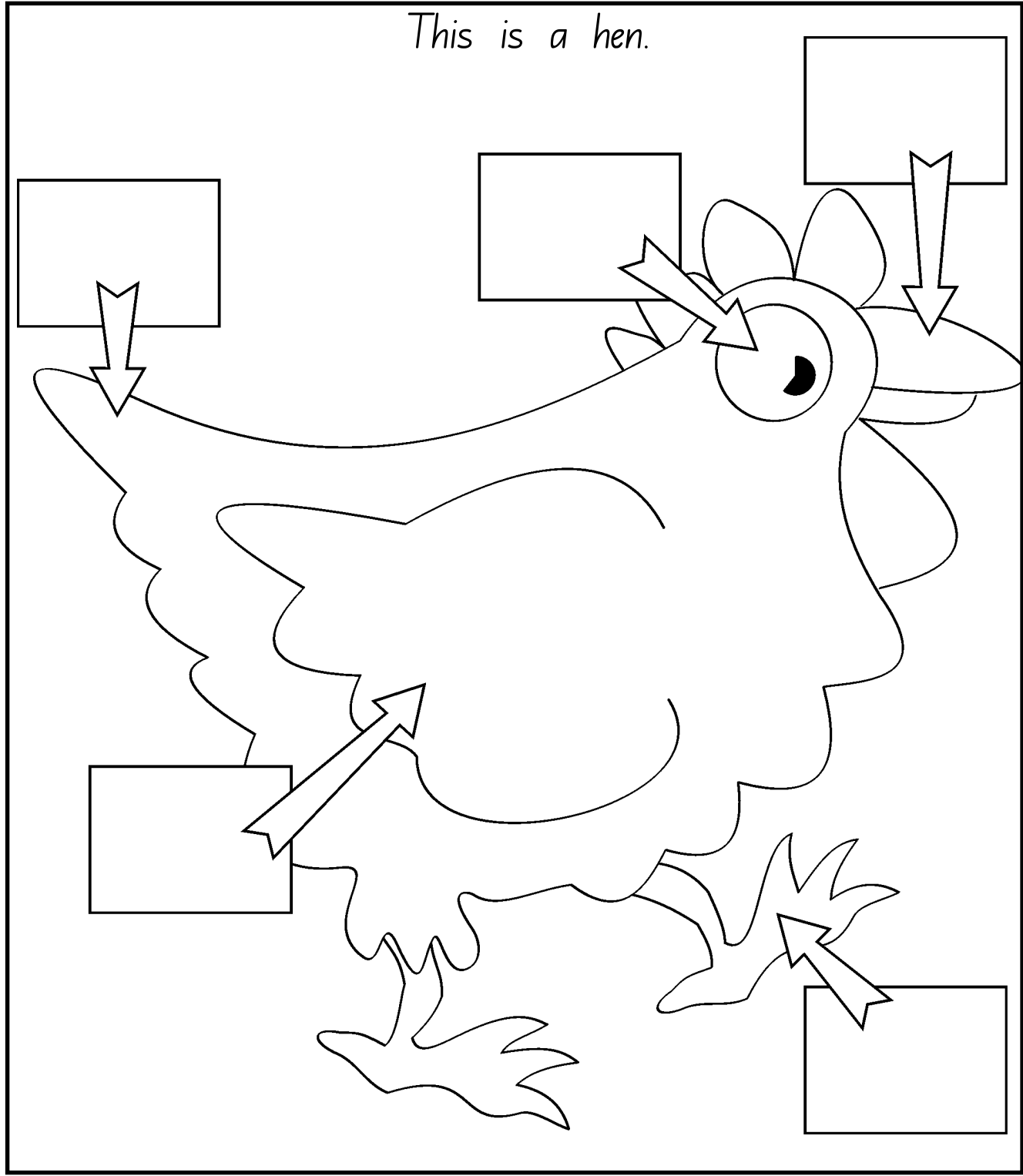

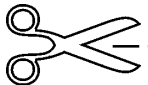
 Cut and paste the words into their correct place.

tail	wing	foot	eye	beak
------	------	------	-----	------

Fun With Starting Sounds

Name: _____

Circle the correct starting sounds.

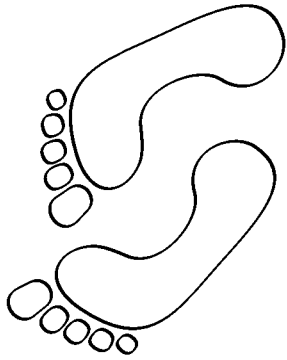
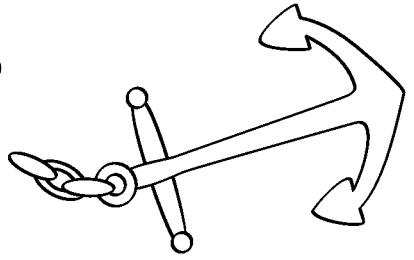
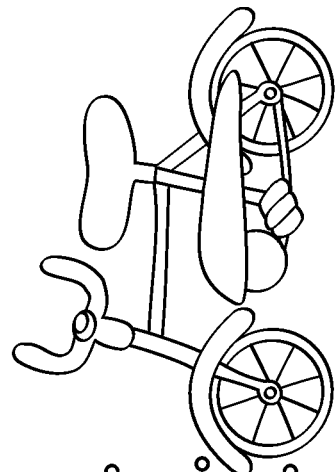
		
<input type="radio"/> g	<input type="radio"/> a	<input type="radio"/> b
<input type="radio"/> f	<input type="radio"/> d	<input type="radio"/> k
<input type="radio"/> b	<input type="radio"/> b	<input type="radio"/> d

Write the starting sounds.

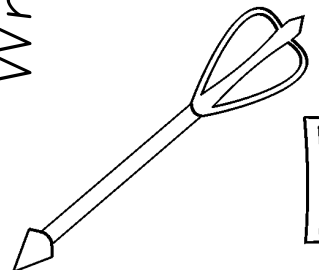
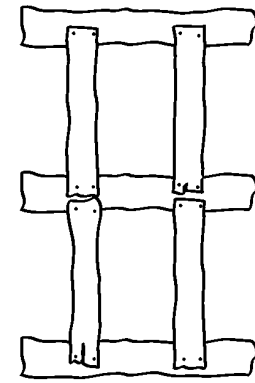
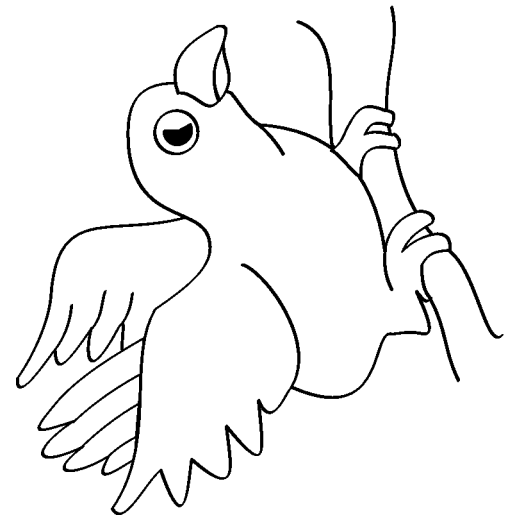
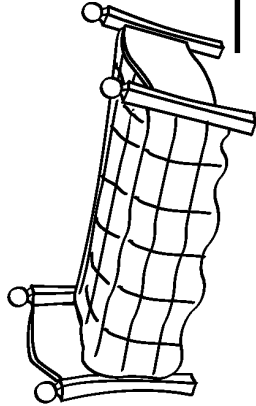
			
_____	_____	_____	_____

Which sound matches the picture?

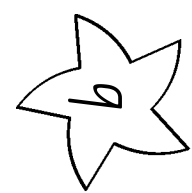
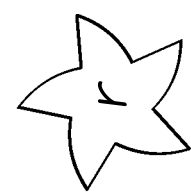
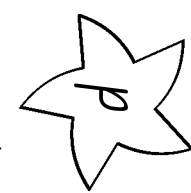
		
---	---	---

Fun With Starting Sounds

Name: _____

Circle the correct starting sounds.

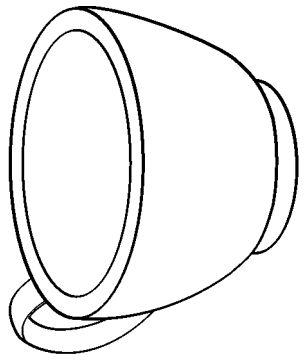
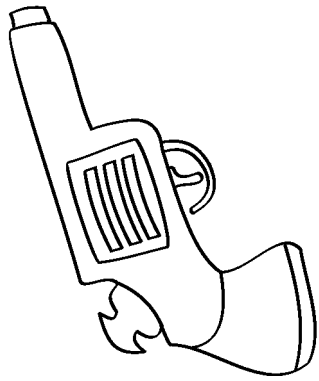
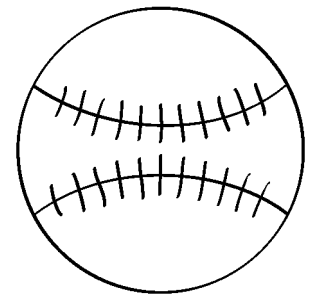
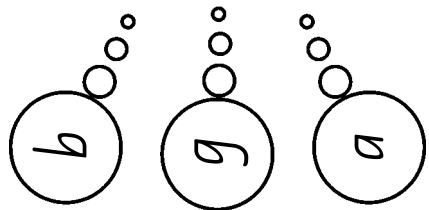

Write the starting sounds.

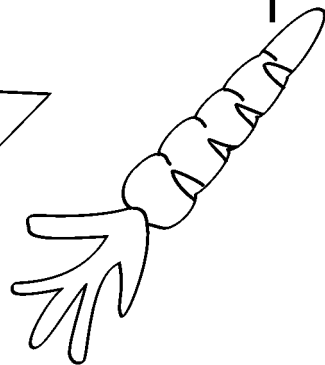
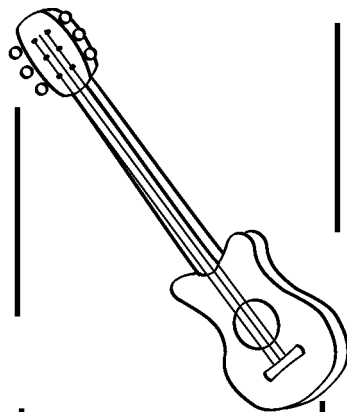
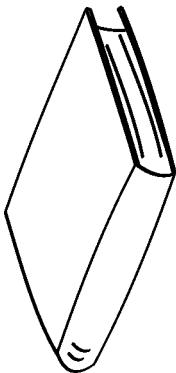
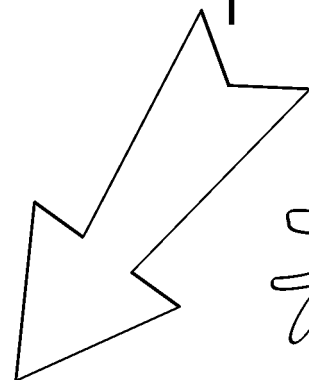

Which sound matches the picture?

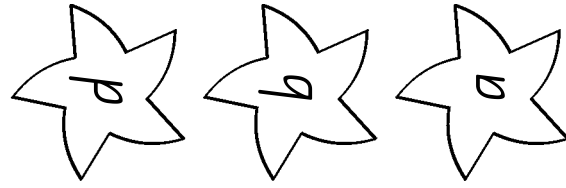
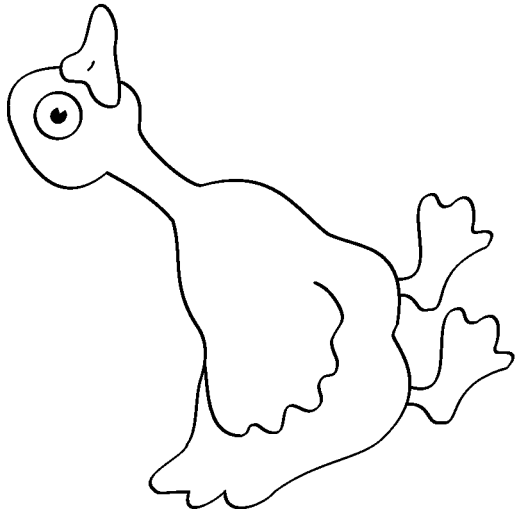

Fun with Labelling

Name: _____

This is a dog.

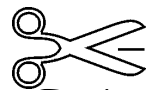
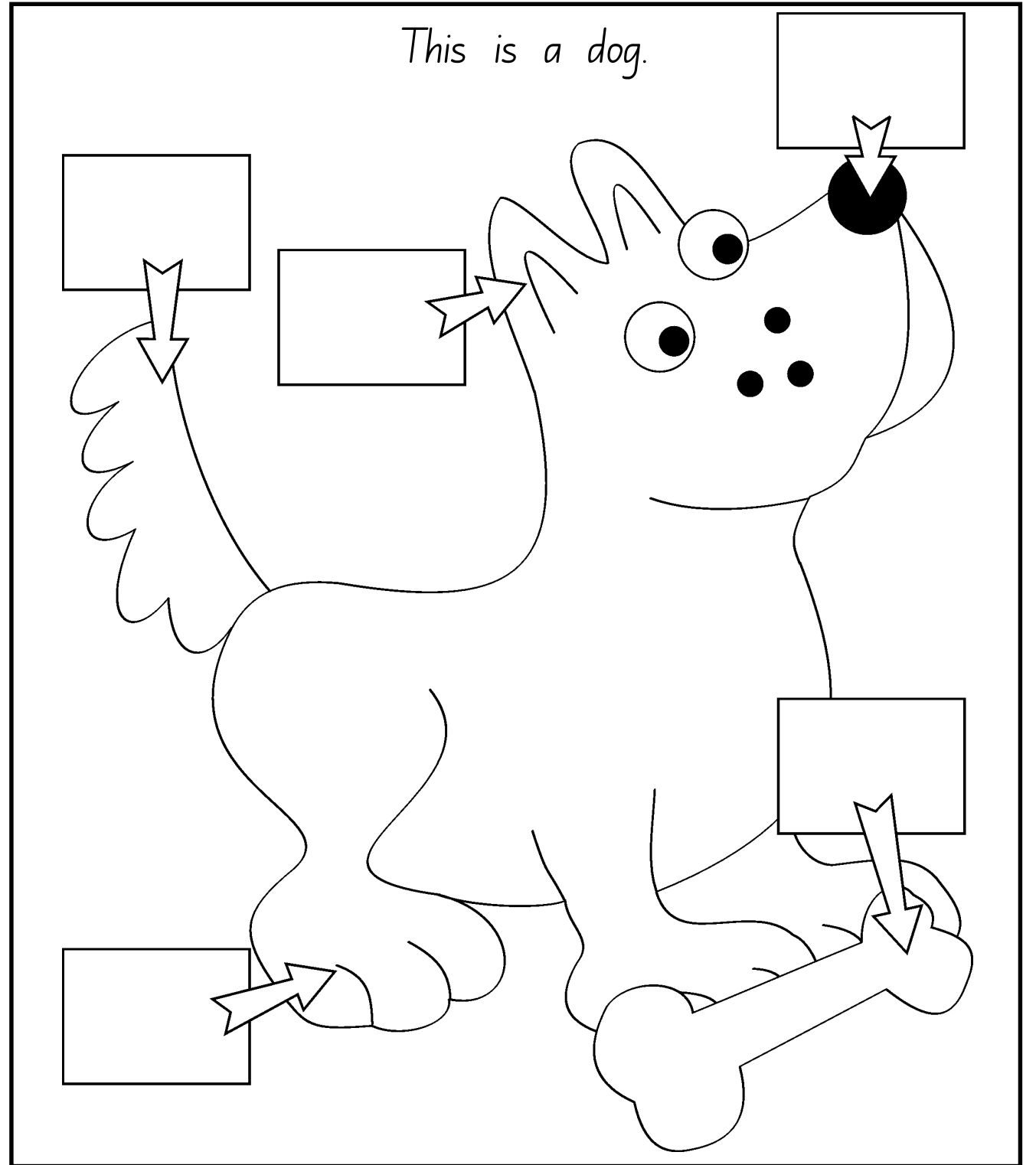

Cut and paste the words into their correct place.

bone	tail	paw	ear	nose
------	------	-----	-----	------

Fun with Labelling

Name: _____

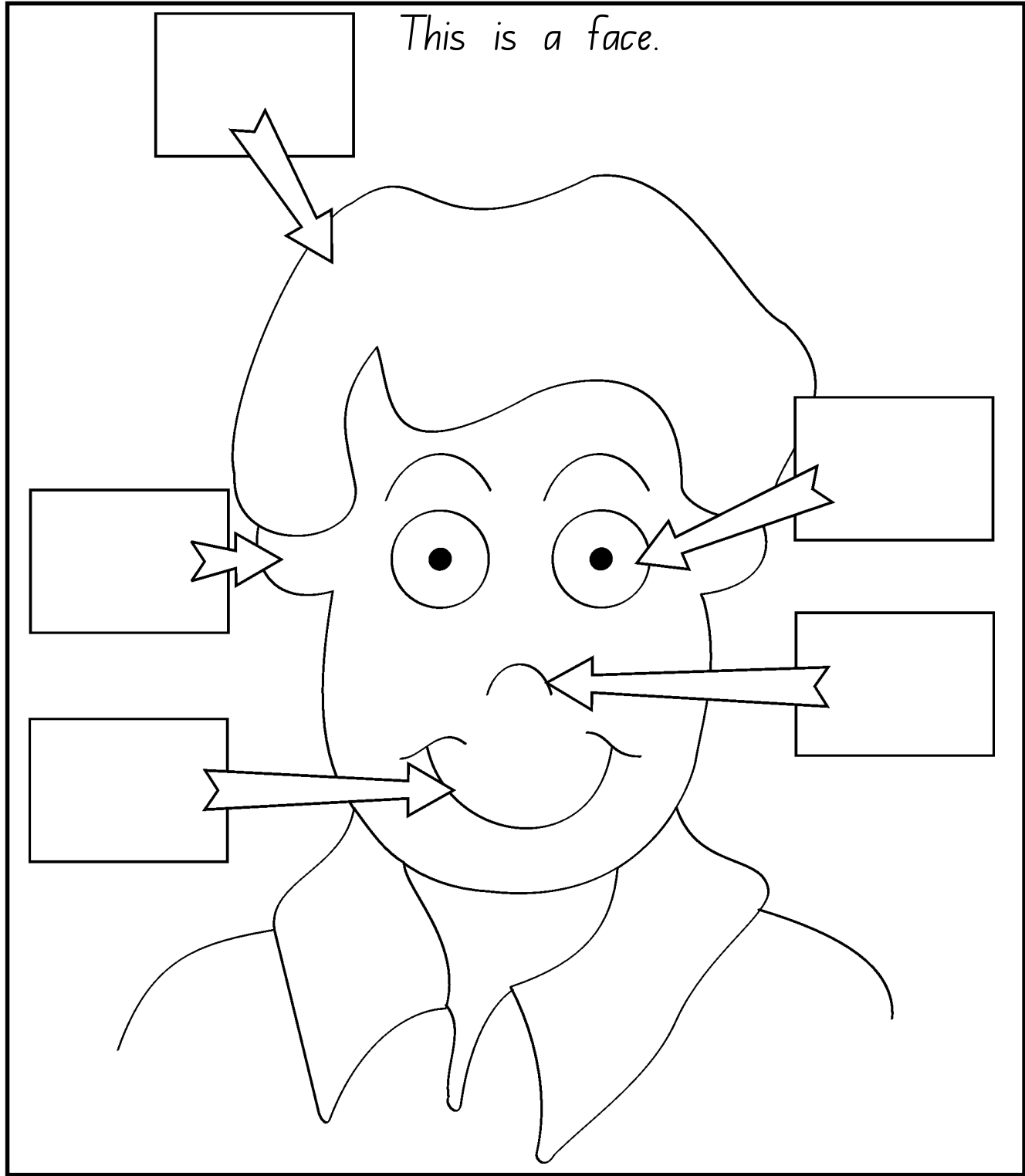

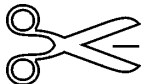
 Cut and paste the words into their correct place.

mouth	eye	nose	ear	hair
-------	-----	------	-----	------

Fun With Starting Sounds

Name: _____

Circle the correct starting sounds.

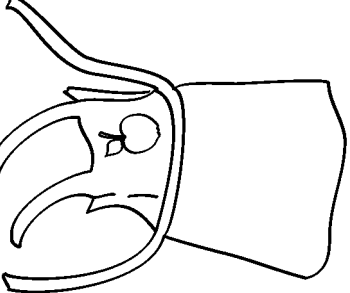
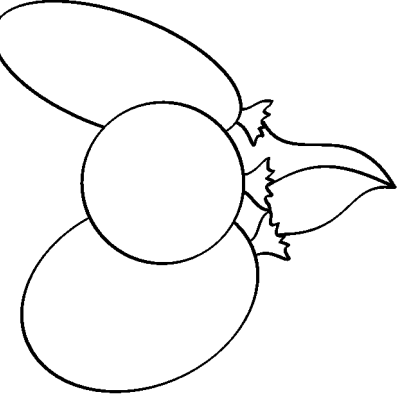
		
d... b... g...	n... a... p...	a... b... c...

Write the starting sounds.

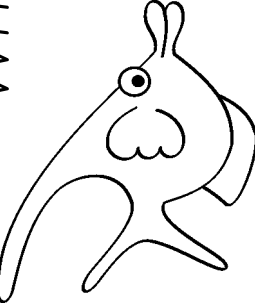
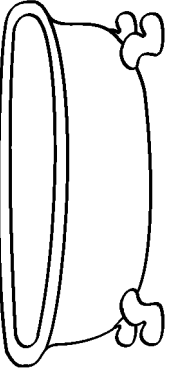
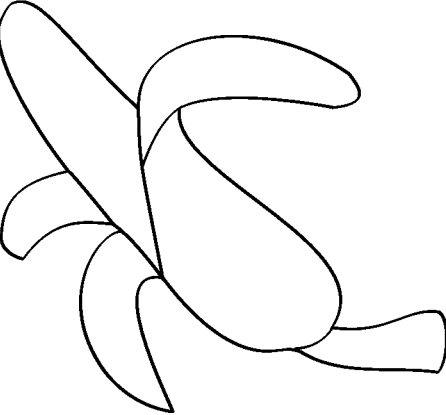
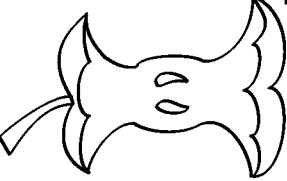
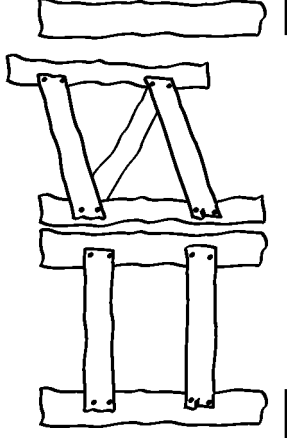
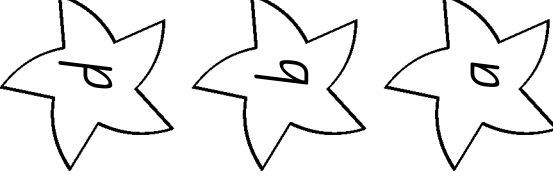
		
_____	_____	_____
		
_____	_____	_____

Which sound matches the picture?

Fun With Starting Sounds

Name: _____

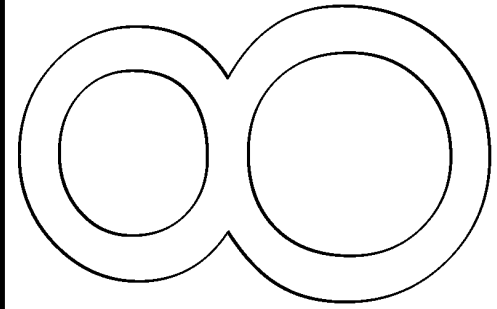

t g e

Circle the correct starting sounds.

a n h

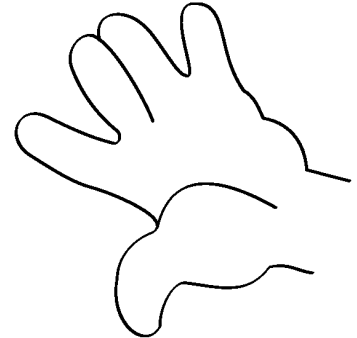

e j g

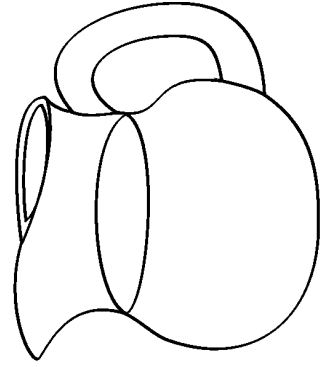

Write the starting sounds.

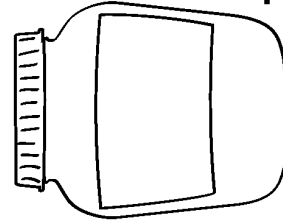
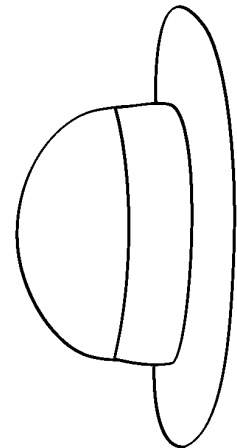
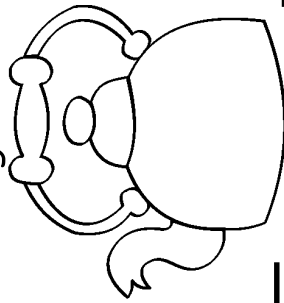
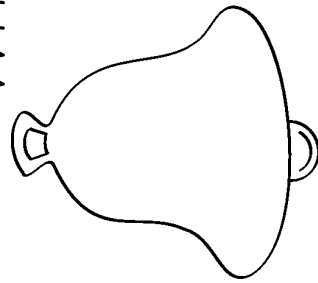

Which sound matches the picture?

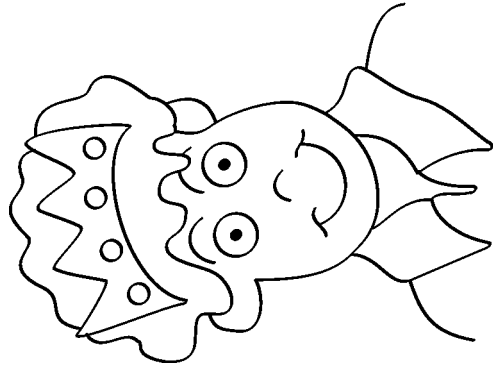

i k g

Fun with Labelling

Name: _____

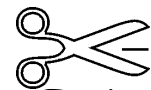
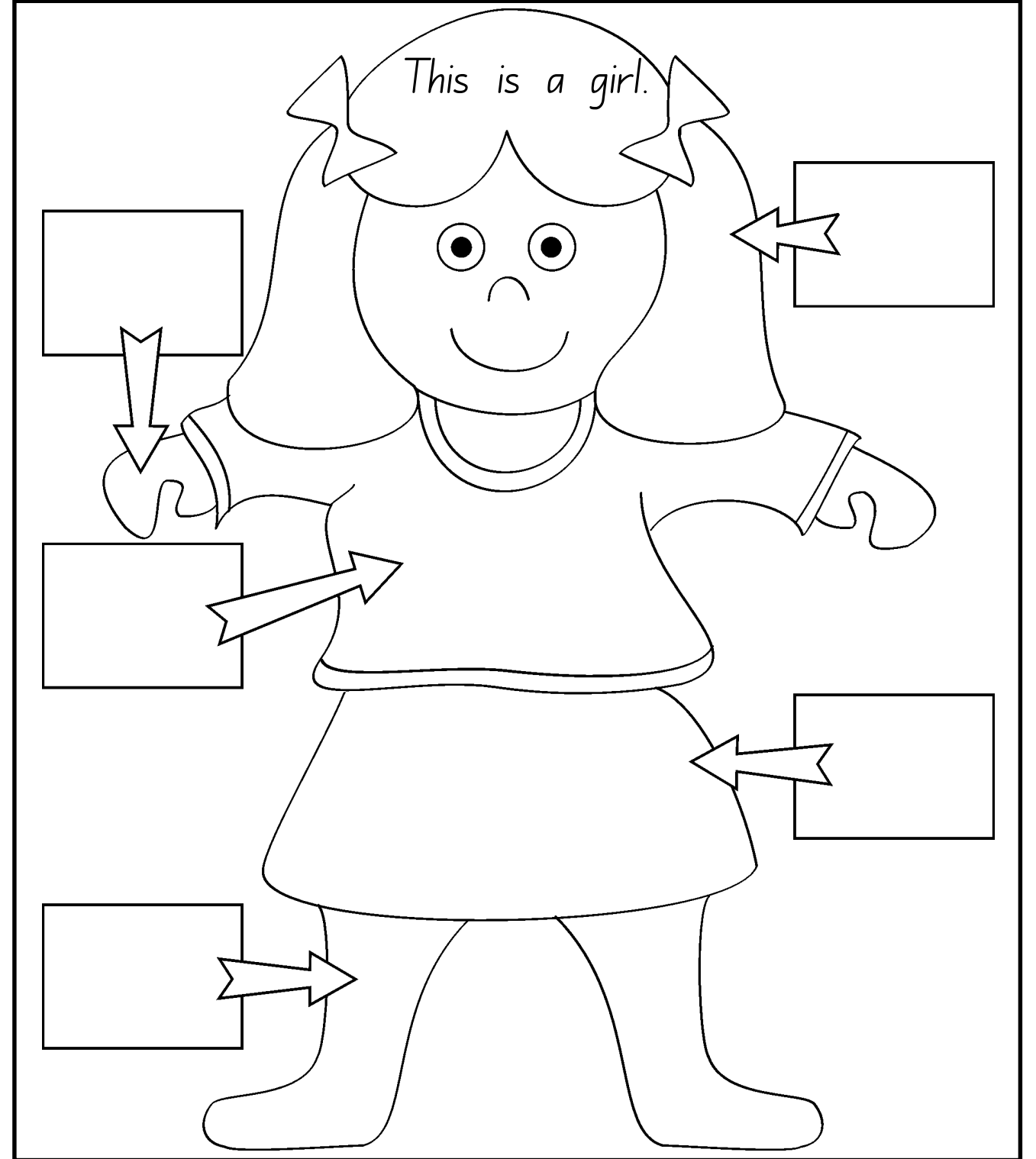

Cut and paste the words into their correct place.

hair

hand

leg

t-shirt

skirt

Fun with Labelling

Name: _____

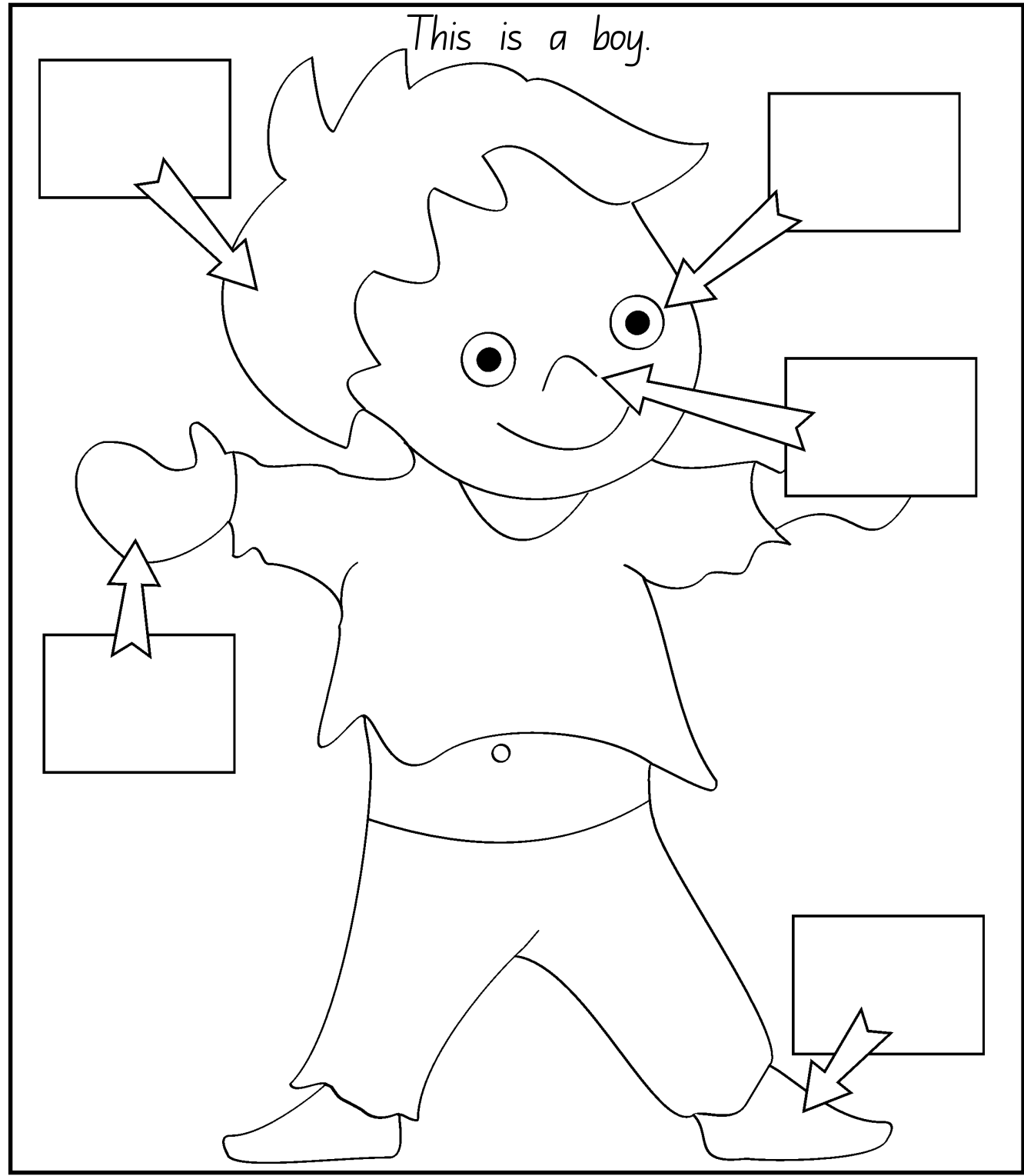

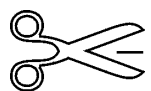
 Cut and paste the words into their correct place.

hand	foot	eye	nose	hair
------	------	-----	------	------

Fun With Starting Sounds

Name: _____

Match the pictures to the starting sounds.

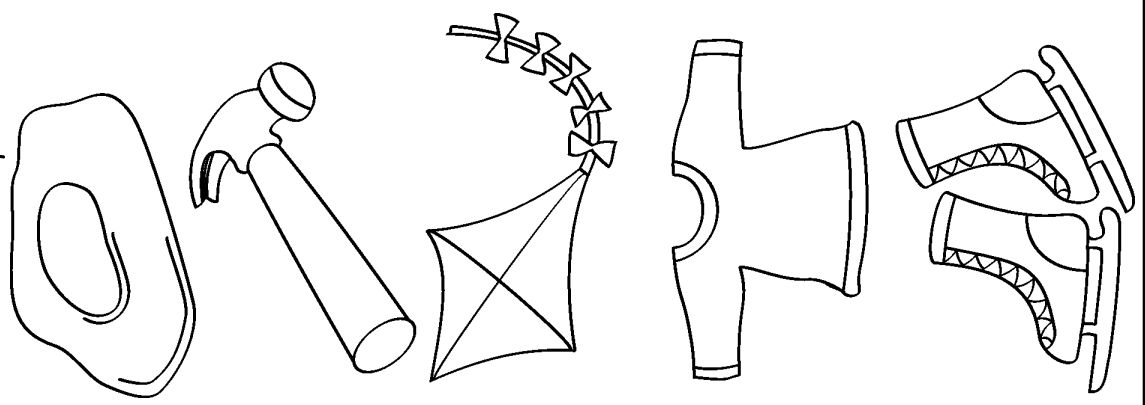

j i e h k

Circle the correct starting sound.

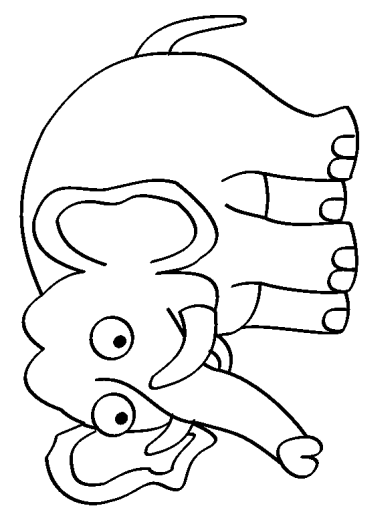
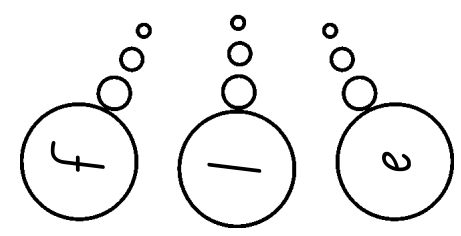



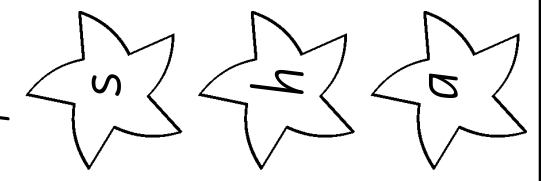
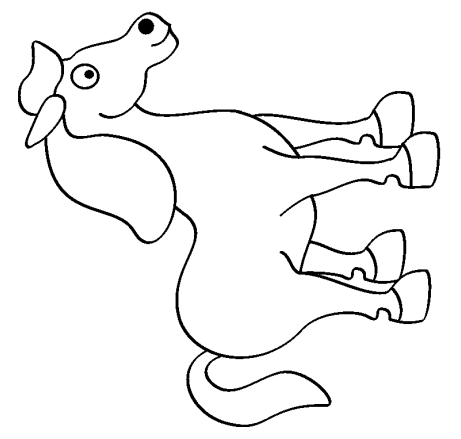





Which sound matches the picture?

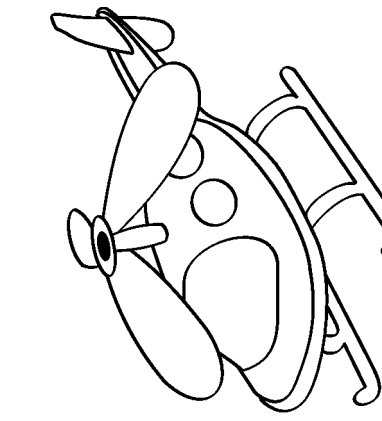

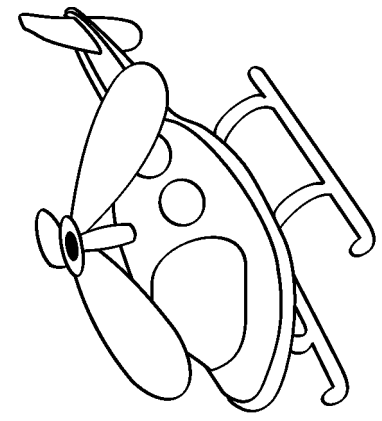
Fun With Starting Sounds

Name: _____

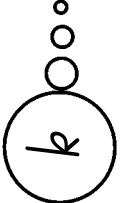
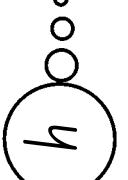
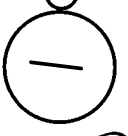
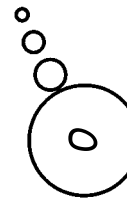
Circle the correct starting sounds.

Write the starting sounds.

	_____
	_____
	_____
	_____

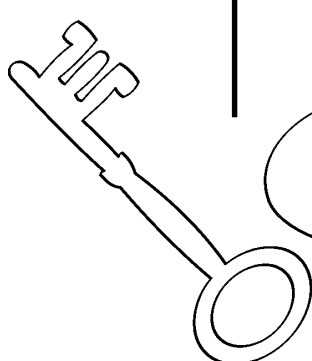
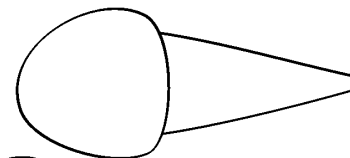
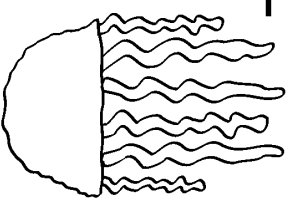
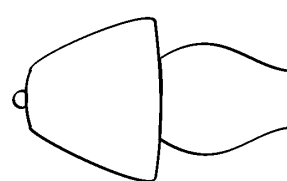

Which sound matches the picture?

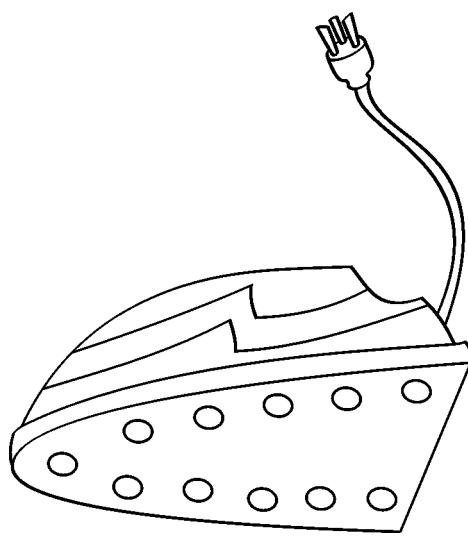
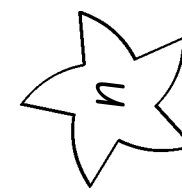
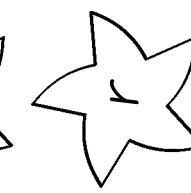
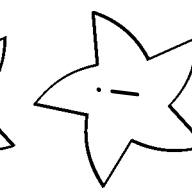
	_____
	
	

Fun With Labelling

Name: _____

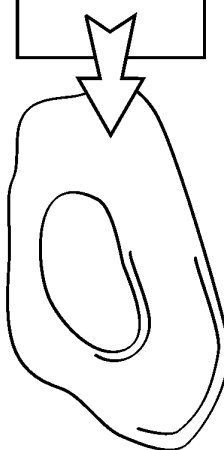
Match the pictures to the words.

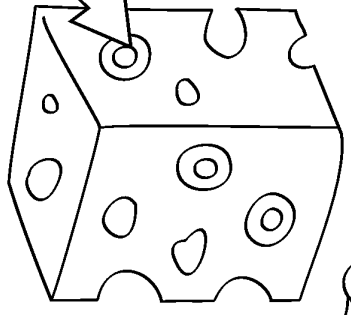
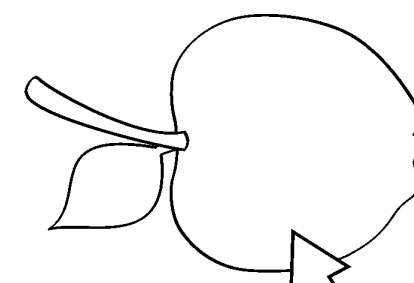
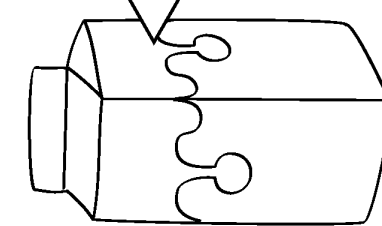
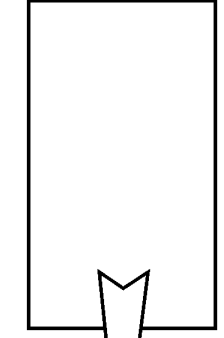
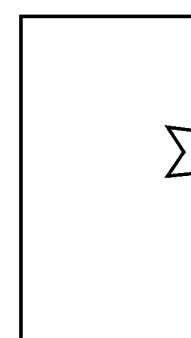
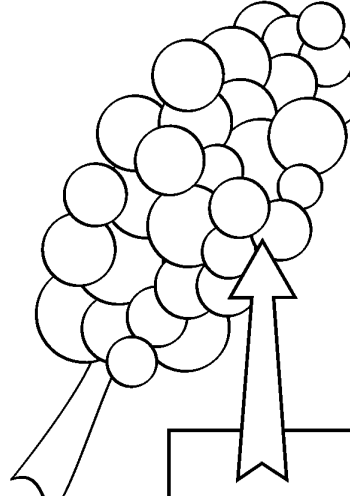
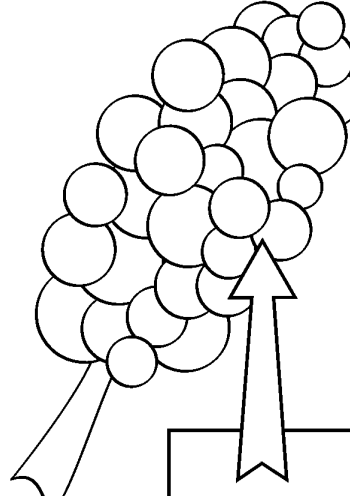
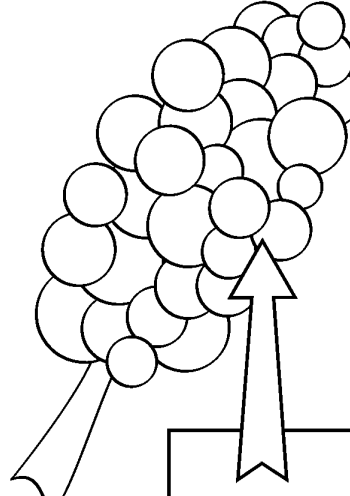
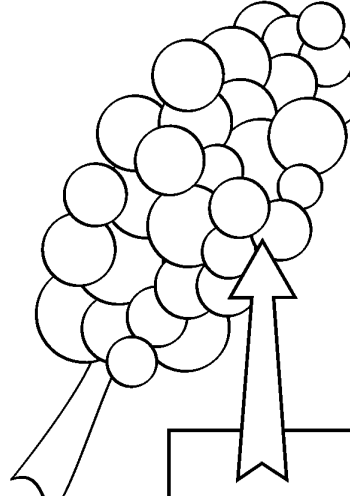
			
_____	_____	_____	_____
			
_____	_____	_____	_____
			
_____	_____	_____	_____

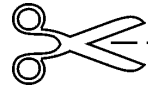

cut and paste

grapes	pie	bread	milk	egg	apple	cheese
--------	-----	-------	------	-----	-------	--------

Fun With Labelling

Name: _____

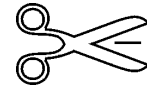

cut and paste

- bike
- bus
- rocket
- car
- van
- helicopter
- jet

Match the pictures to the words.

Fun With Starting Sounds

Name: _____

Match the pictures to the starting sounds.

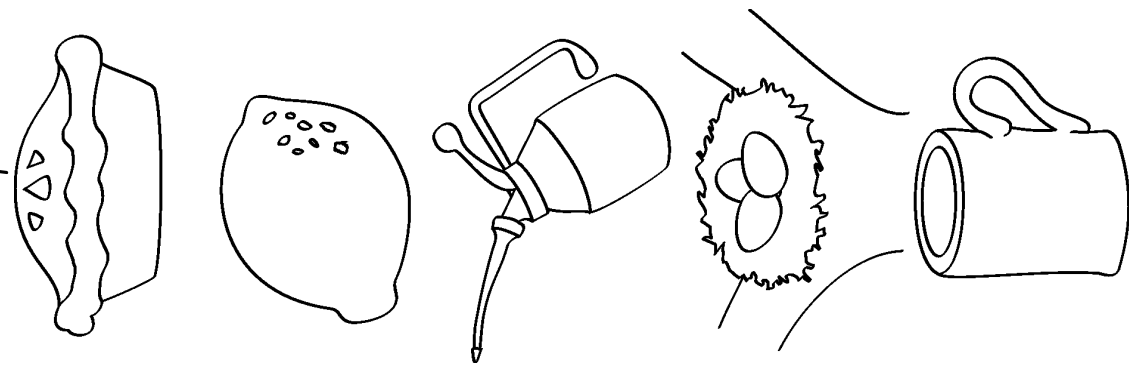

n

m

o

p

l

Circle the correct starting sound.

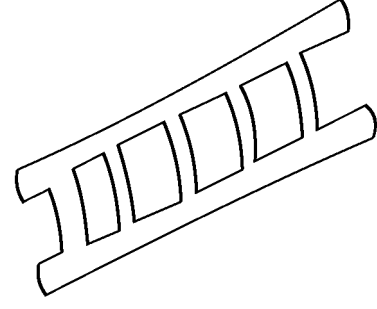
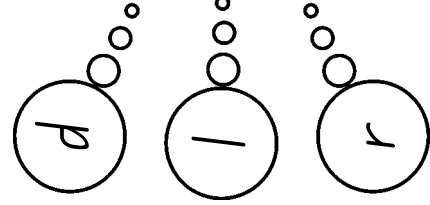

Which sound matches the picture?

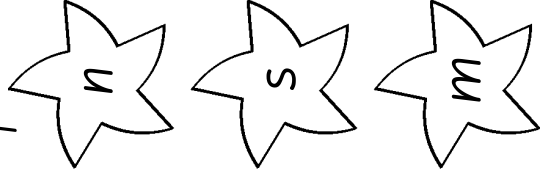
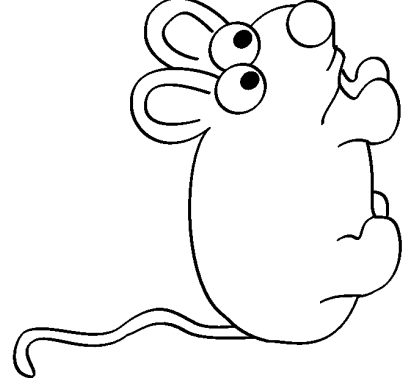

Fun With Starting Sounds

Name: _____

Circle the correct starting sounds.

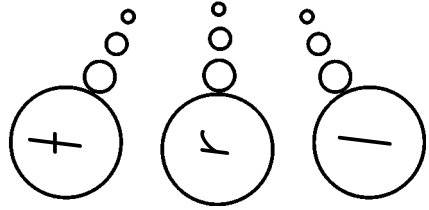

t

r

l

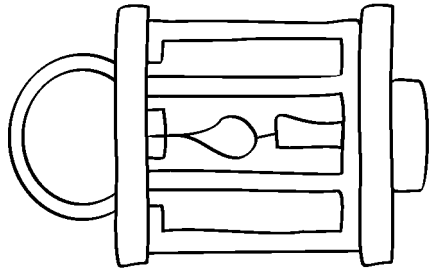

o

p

s

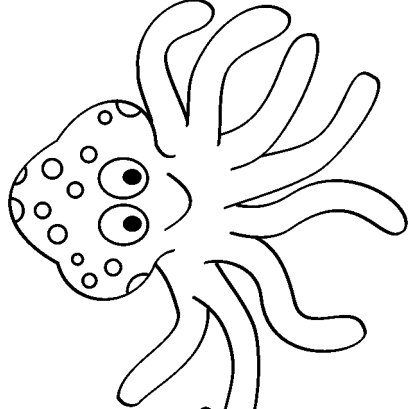

s

m

n

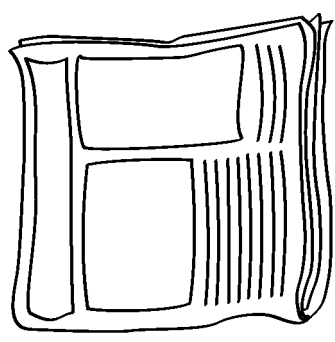

Write the starting sounds.

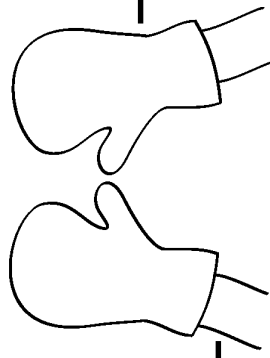
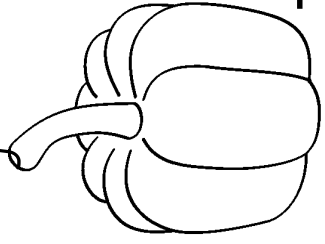
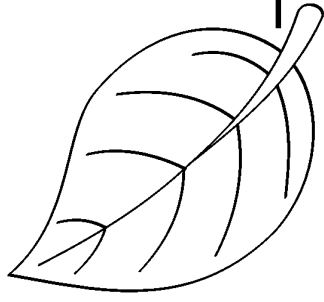
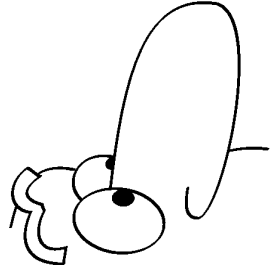

Which sound matches the picture?

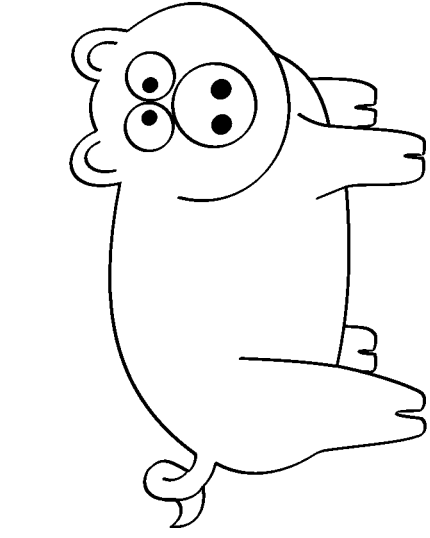

p g b

Fun With Labelling

Name: _____

Match the pictures to the words.

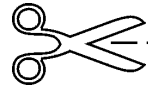
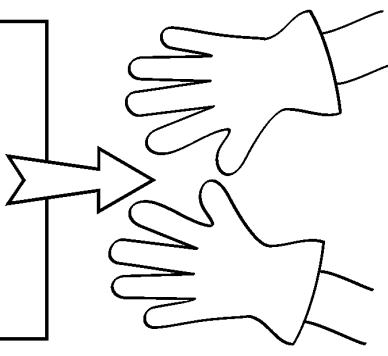
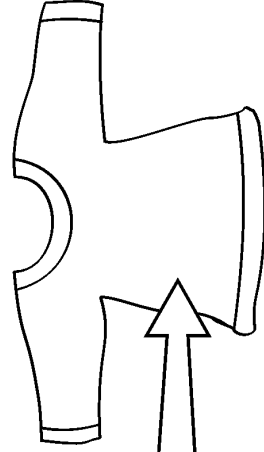
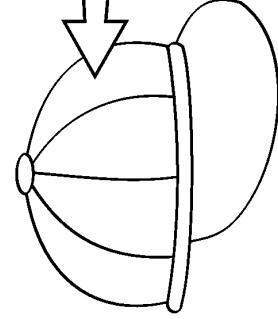
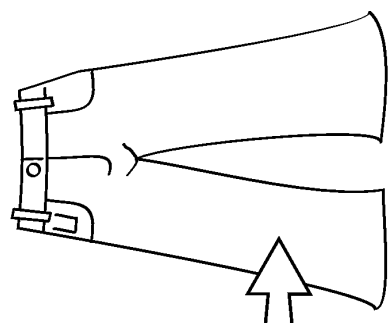
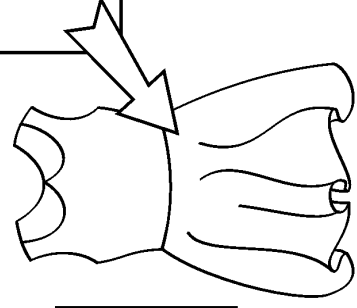
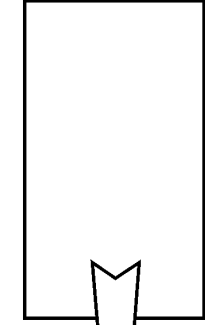
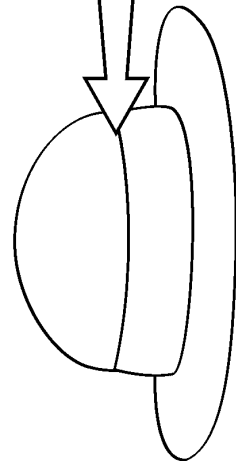

cut and paste

cap

jumper

sock

gloves

hat

jeans

dress

Fun With Labelling

Name: _____

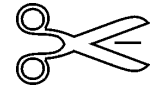

cut and paste

clam

fish

seal

shark

crab

eel

shell

Match the pictures to the words.

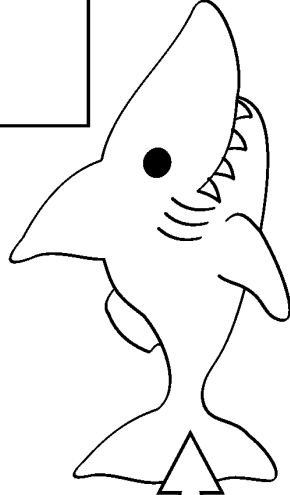
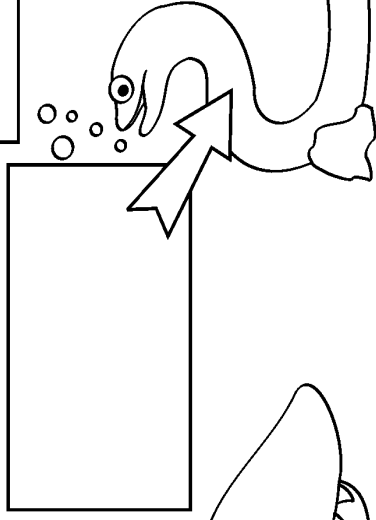
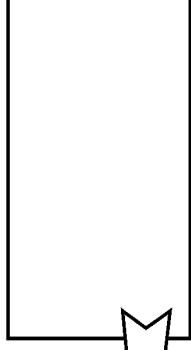
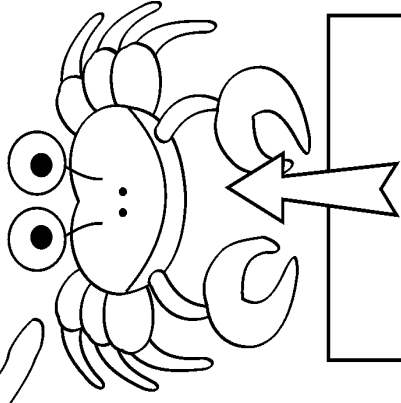
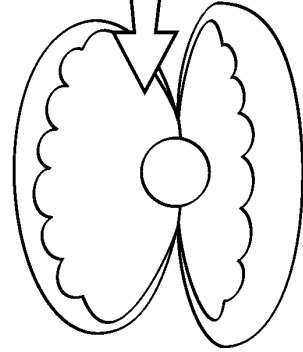
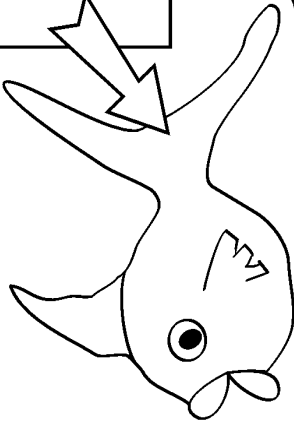
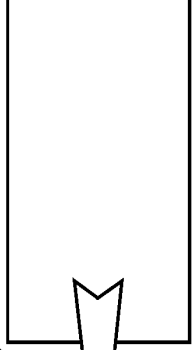
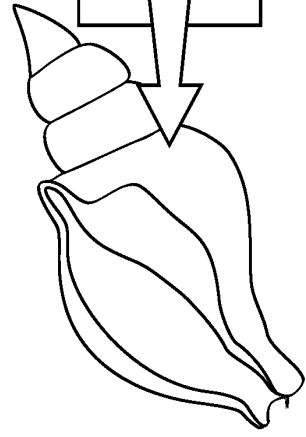

Fun With Starting Sounds

Name: _____

Write the starting sounds.

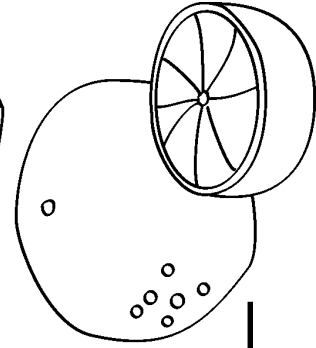
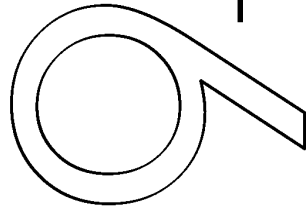
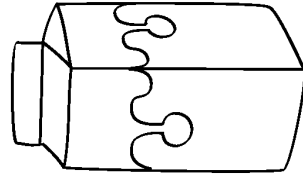
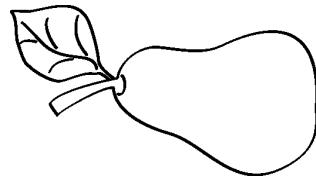

Circle the correct starting sounds.

t o o o
n o o o
m o o o

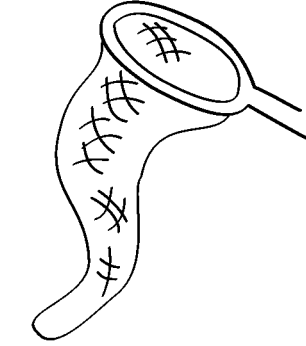

p o o o
e o o o
g o o o

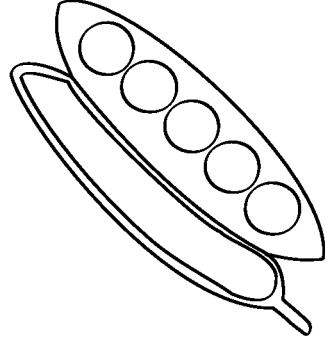

m o o o
p o o o
n o o o

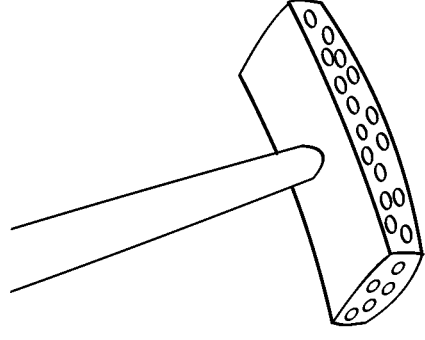

Which sound matches the picture?

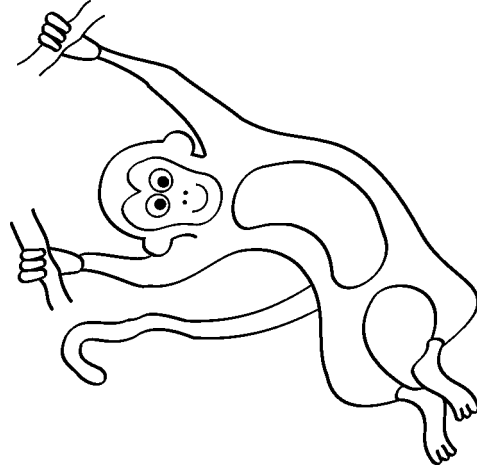

n m k

Fun With Starting Sounds

Name: _____

Match the pictures to the starting sounds.



s

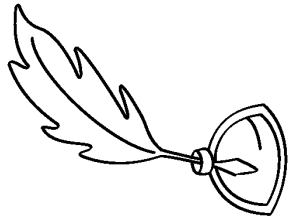

r

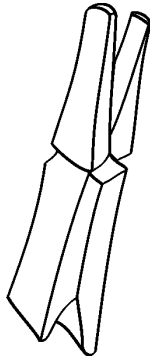

t

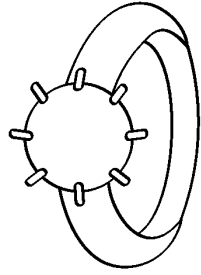

q



p

Circle the correct starting sound.

b

r

d

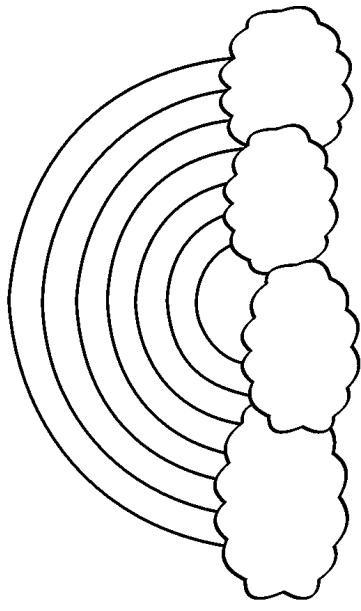

Which sound matches the picture?

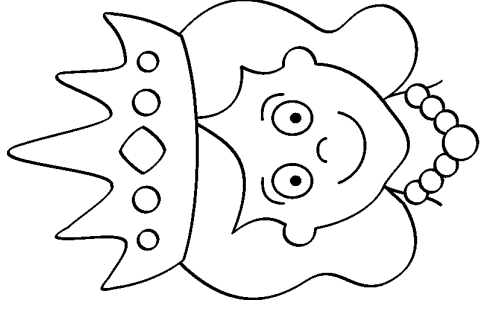

p

q

n

Fun With Labelling

Name: _____

Match the pictures to the words.

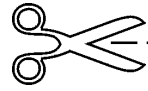
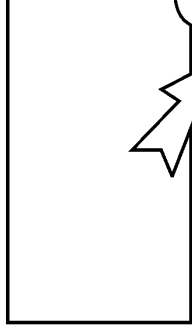
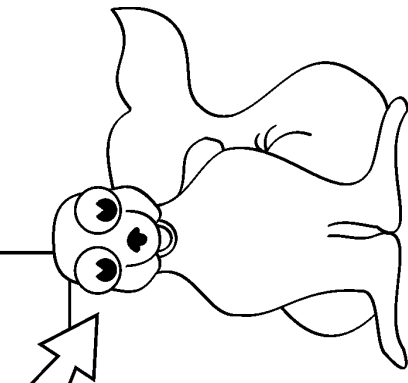
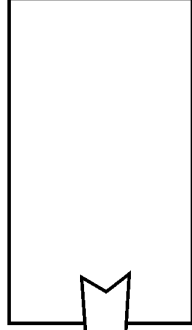
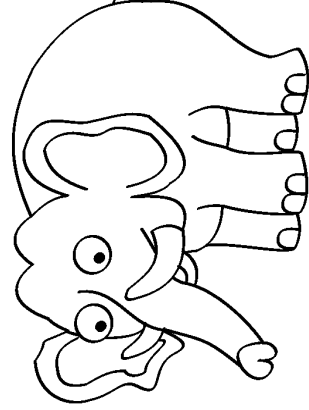
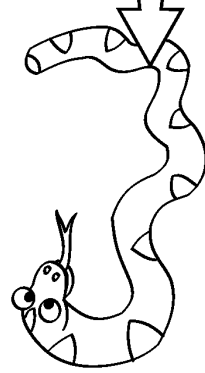
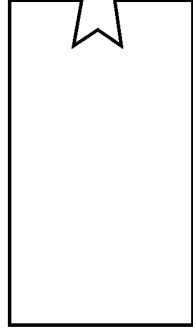
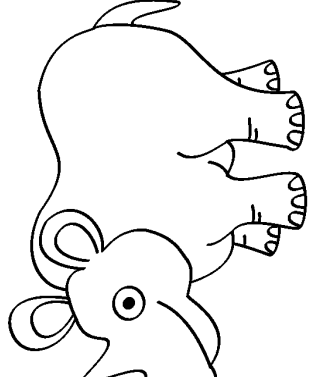
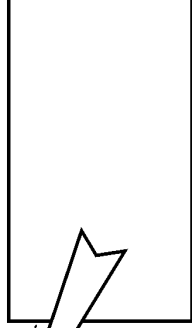

cut and paste

lion

monkey

snake

rhino

tiger

seal

elephant

Fun With Labelling

Name: _____

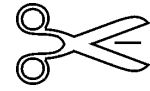

cut and paste

cow

duck

hen

horse

sheep

pig

donkey

Match the pictures to the words.

Fun With Starting Sounds

Name: _____

Circle the correct starting sounds.

s

r

t

a

p

s

?

s

l

e

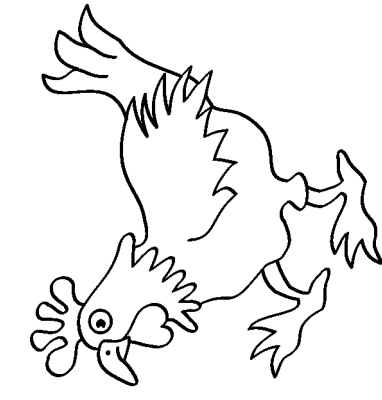
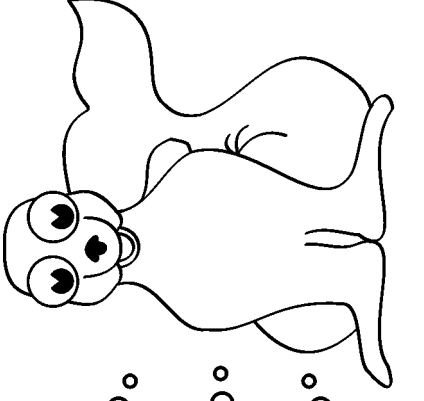

Write the starting sounds.

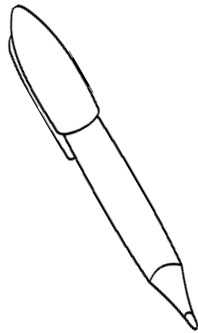

6

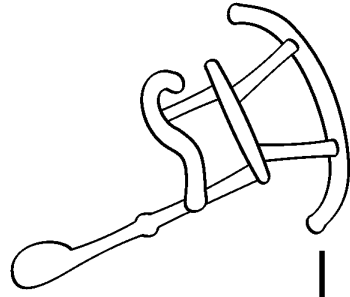
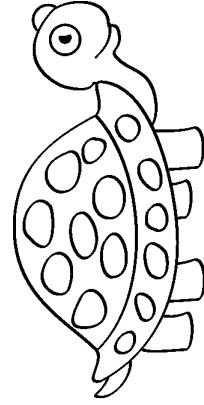

Which sound matches the picture?

s

n

r

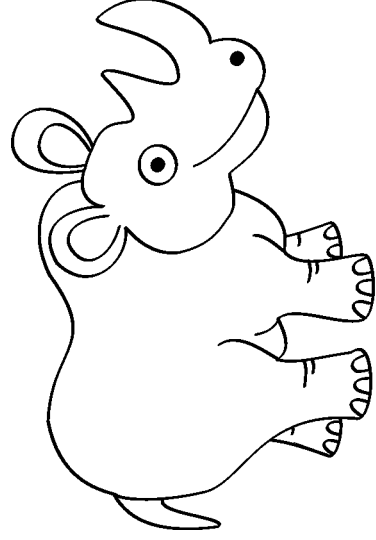

Fun With Starting Sounds

Name: _____

Circle the correct starting sounds.

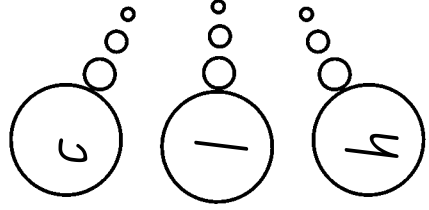
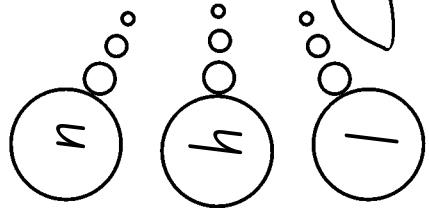
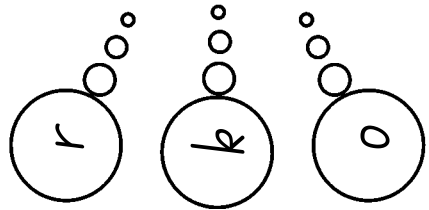

Write the starting sounds.

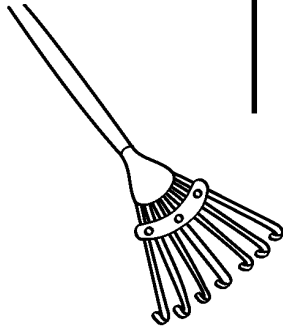
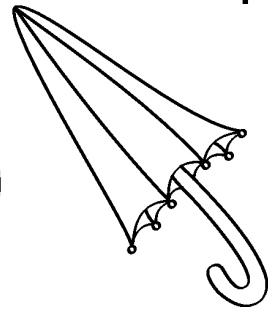
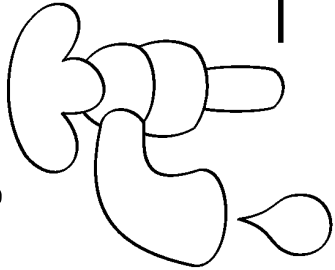
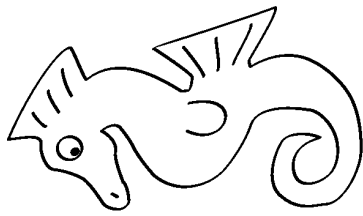

Which sound matches the picture?

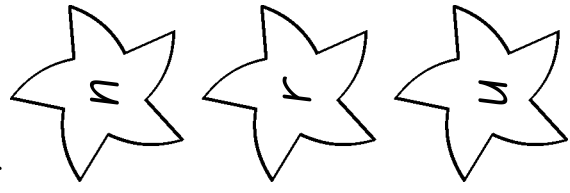

Fun With Labelling

Name: _____

Match the pictures to the words.

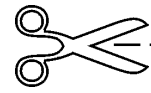

cut and paste

- mouse
- fish
- bird
- cat
- dog
- snail
- spider

Fun With Starting Sounds and Sentences

Name: _____

Which word matches the picture?

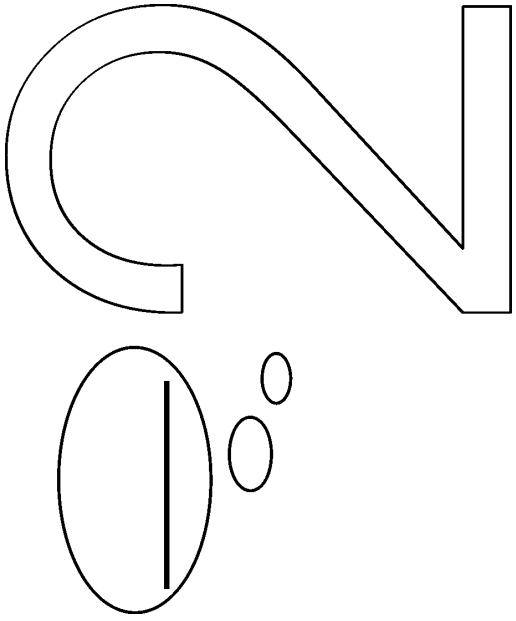

two
too
to

Read and Draw

Here is a train.

True or False?

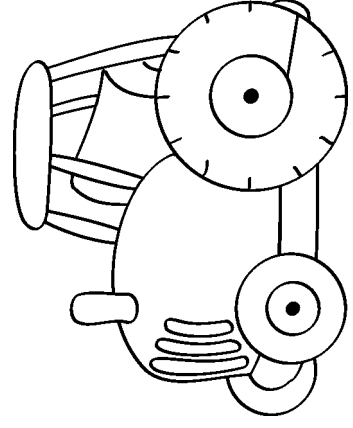

Here is a tractor.

f a l s e

Which word starts with **t**?

at

ate

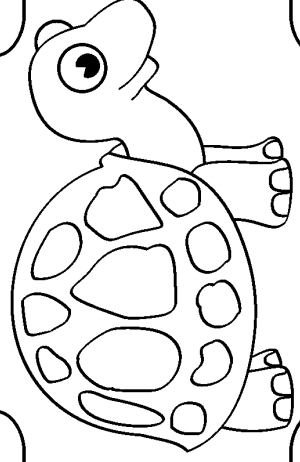

it

to

Fun With Starting Sounds

Name: _____

Match the pictures to the starting sounds.

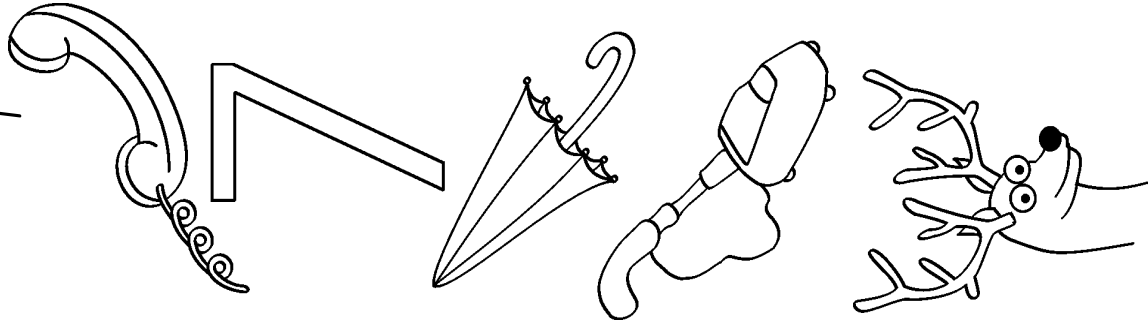

u u r t s

Circle the correct starting sound.

r
q
t

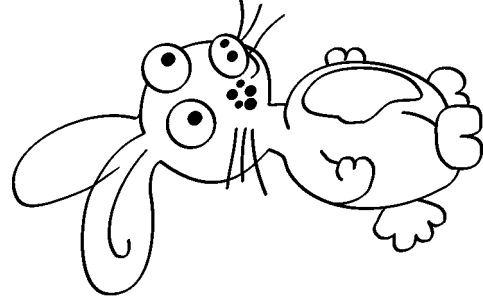

Which sound matches the picture?

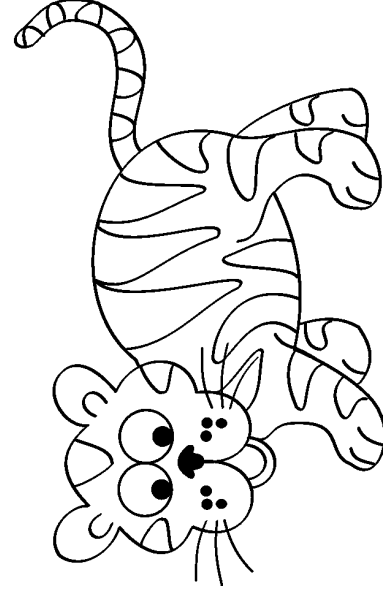

r g t

Fun With Starting Sounds

Name: _____

Circle the correct starting sounds.

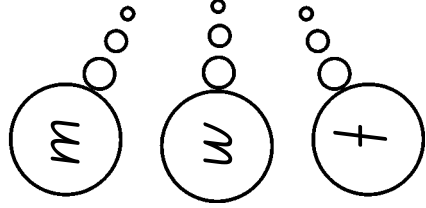

m

w

t

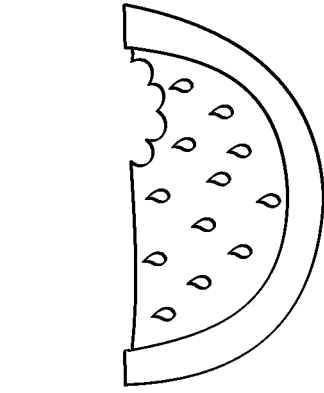

u

s

t

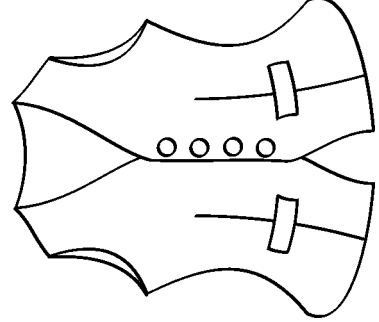

r

x

s

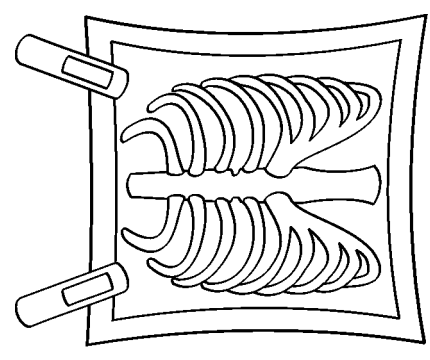

Write the starting sounds.

Which sound matches the picture?

Fun With Starting Sounds and Sentences

Name: _____

Which word matches the picture?

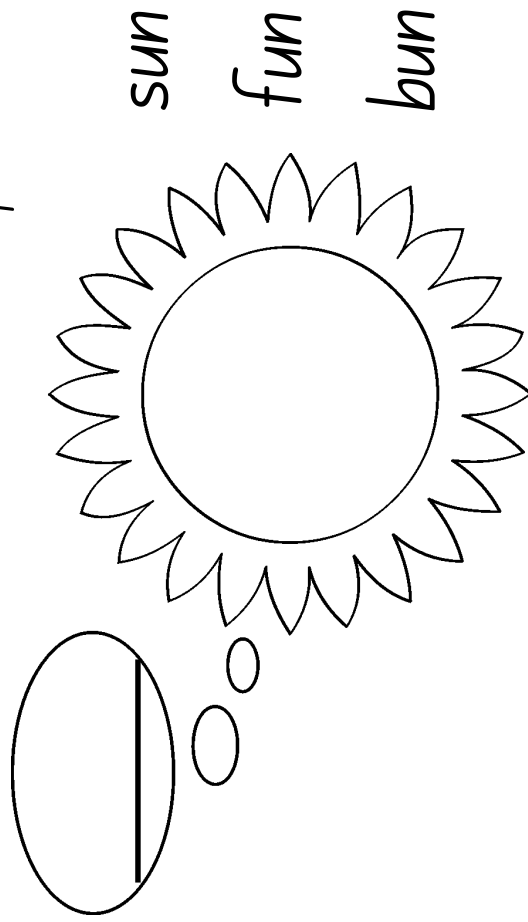

SUN

fun

bun

True or False?

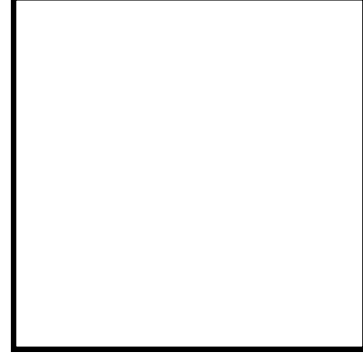

t r u e

f a l s e

Here is a square.

Read and Draw

Which word starts with **a** ?

Here is a star.

Fun With Starting Sounds and Sentences

Name: _____

Which word matches the picture?

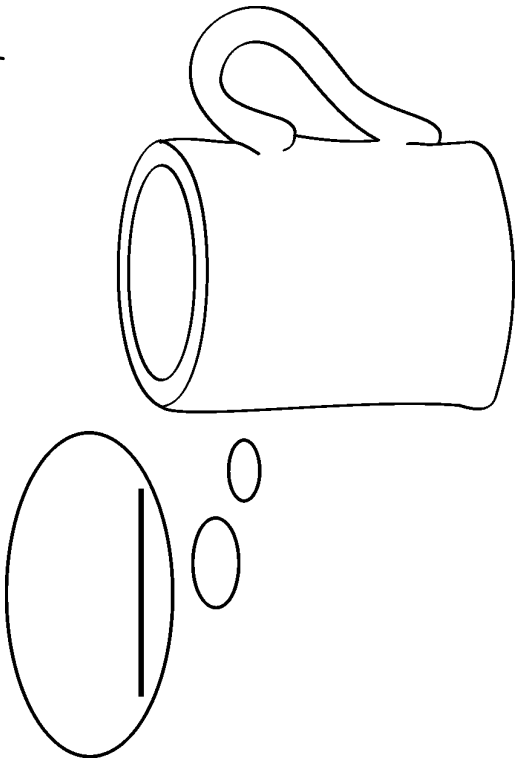

mug
mop
map

True or False?

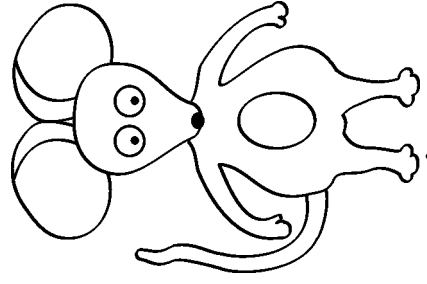

f a l s e

Here is a mat.

Read and Draw

Here is the moon.

Which word starts with **m**?

me

no

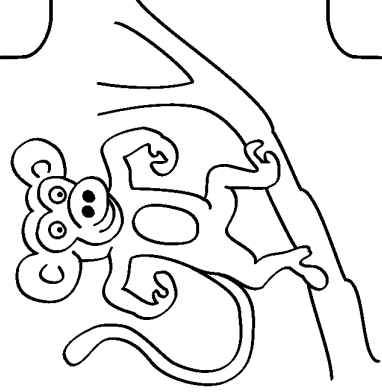

am

an

Fun With Starting Sounds

Name: _____

Circle the correct starting sounds.

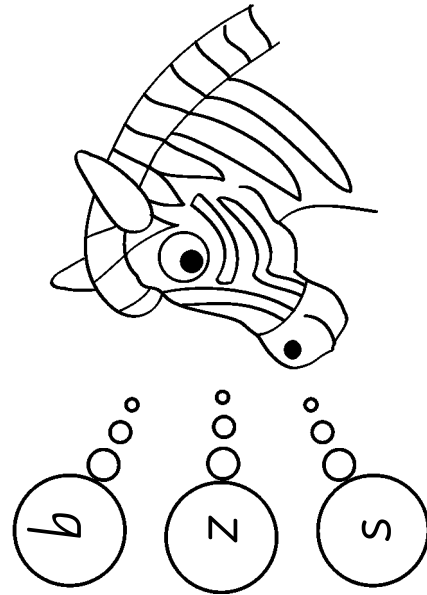

b

r

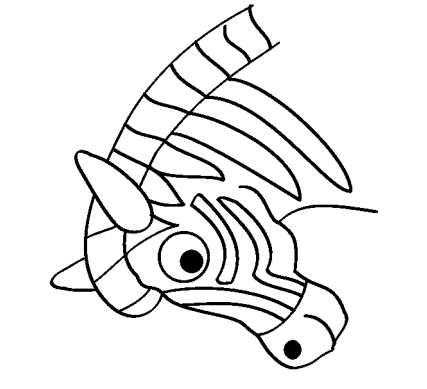

z

w

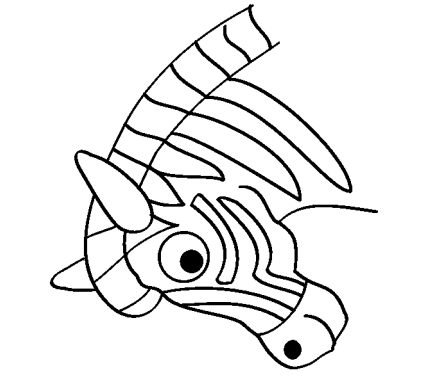

s

m



y

u

t

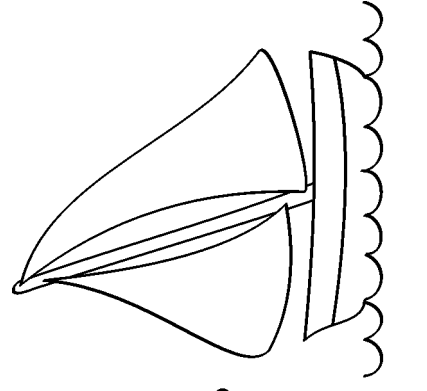

Write the starting sounds.

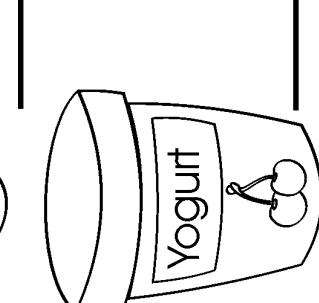
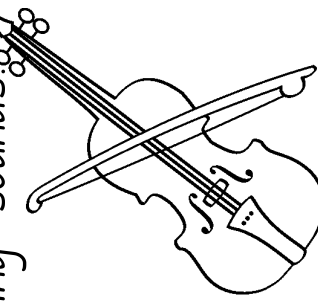

Which sound matches the picture?

s

x

n

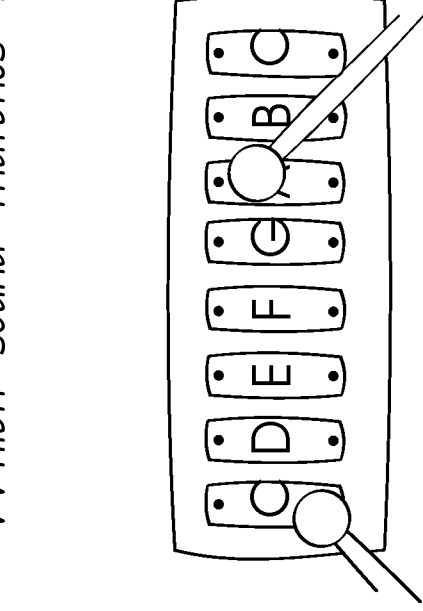

Fun With Starting Sounds and Drawing

Name: _____

Draw a picture for each word.

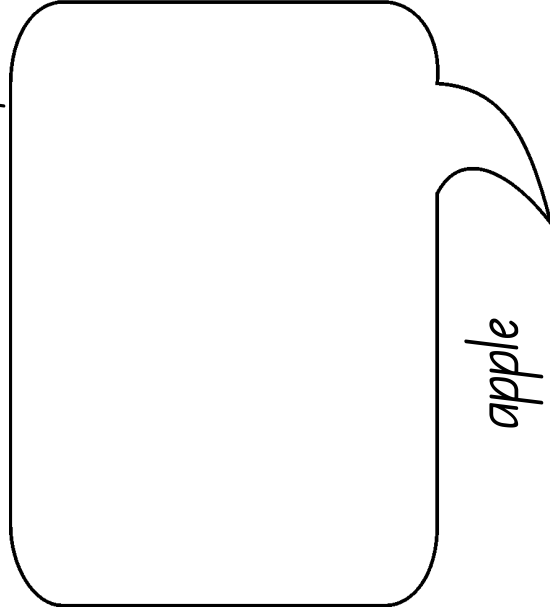

apple

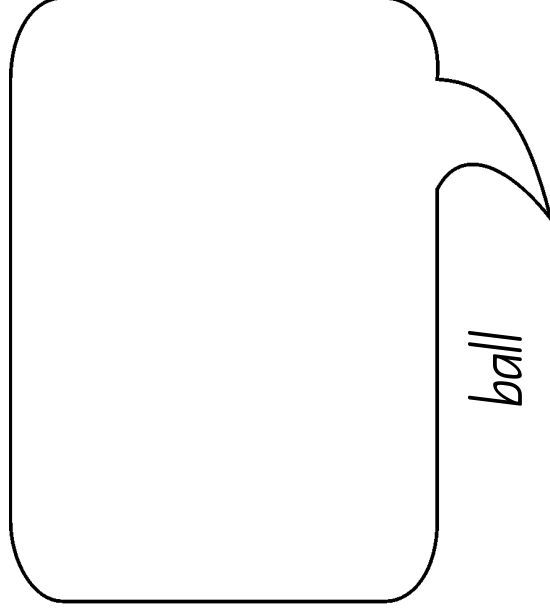

ball

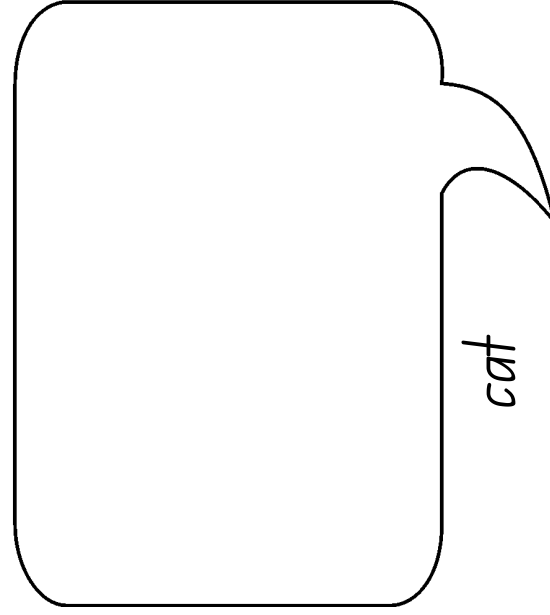

cat

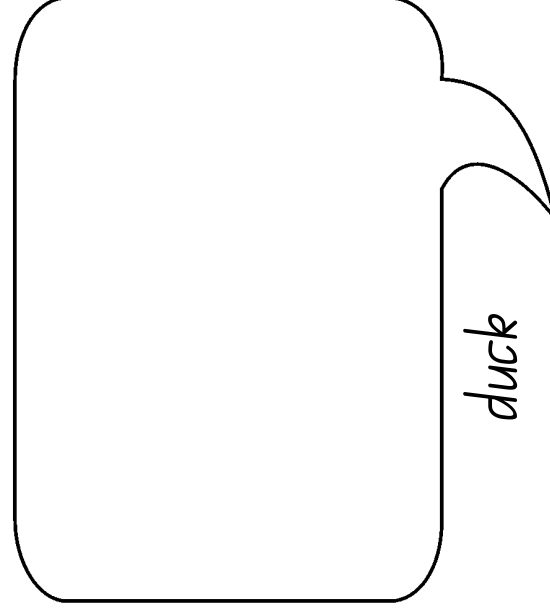

duck

Starting sounds:

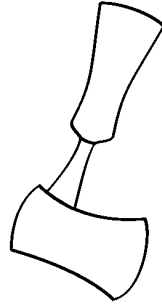
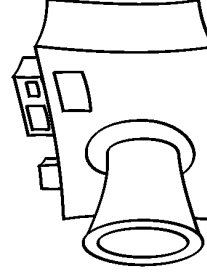
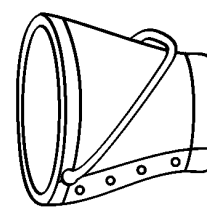
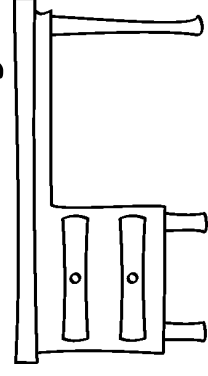

Fun With Starting Sounds and Sentences

Name: _____

Which word matches the picture?

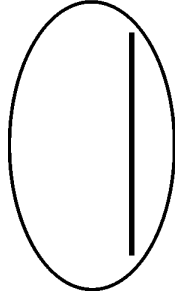

hot

hat

hit



True or False?

f a l s e

Here is a hand.

Read and Draw

Here is my house.

Which word starts with **a** ?

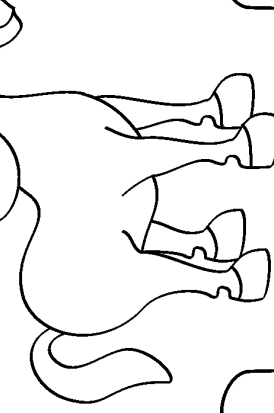
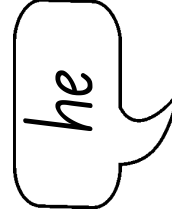

Fun With Starting Sounds and Sentences

Name: _____

Which word matches the picture?

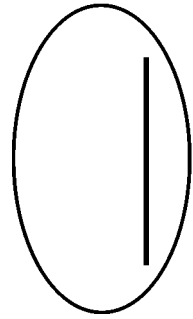

big
bib
bag

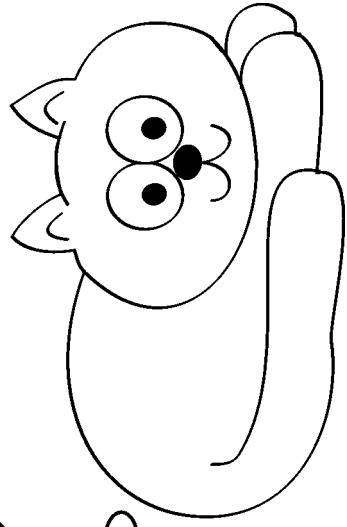

True or False?

f a l s e

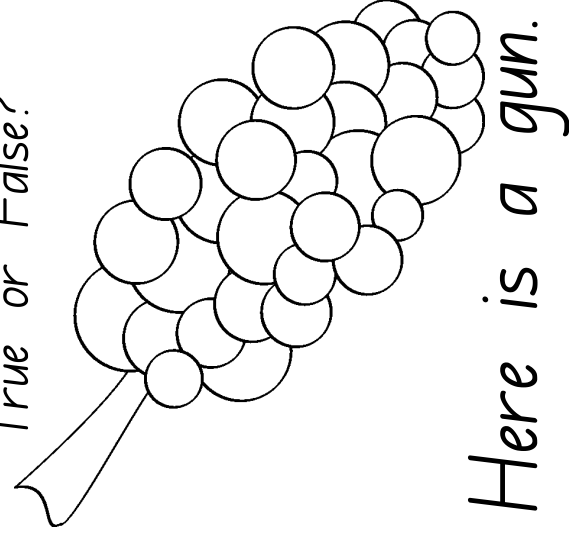

Here is a gun.

Read and Draw

Here is a girl.

Which word starts with **g**?

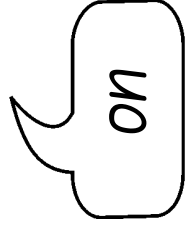
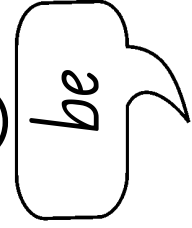
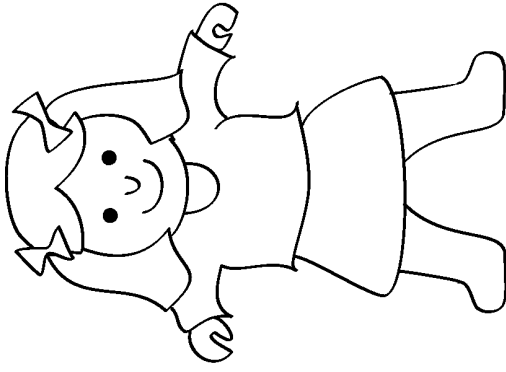
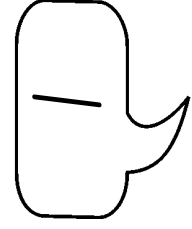

Fun With Starting Sounds and Drawing

Name: _____

Draw a picture for each word.

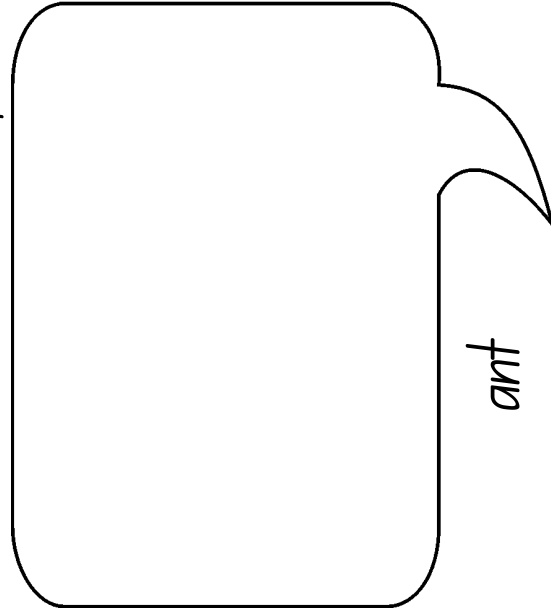

ant

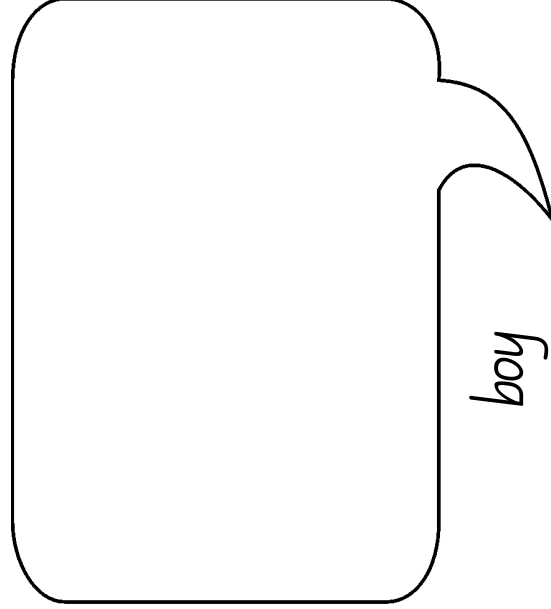

boy

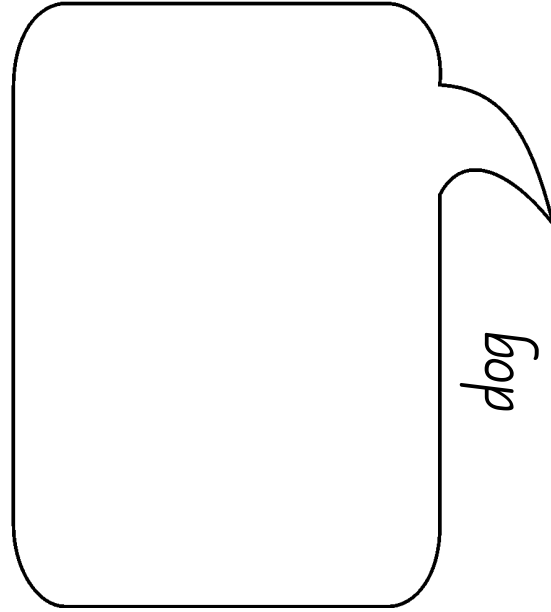

dog

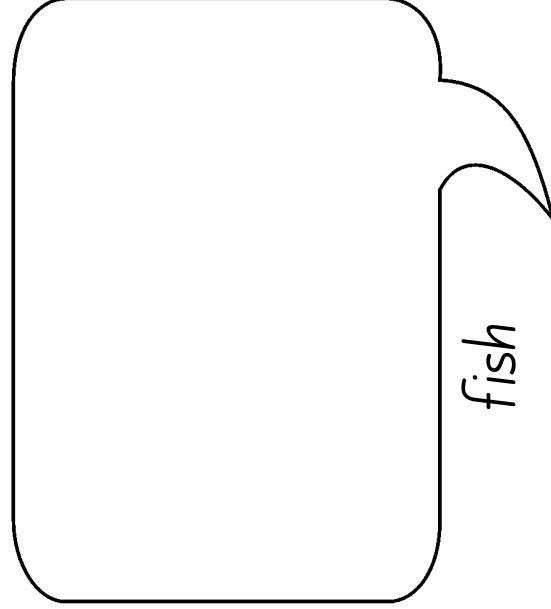

fish

Starting sounds:

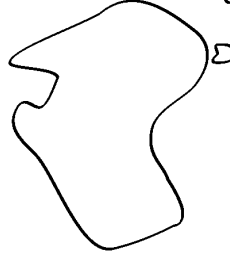
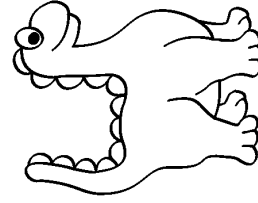
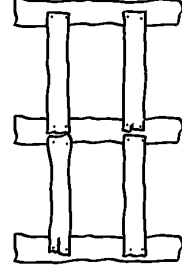

Fun With Starting Sounds and Drawing

Name: _____

Draw a picture for each word.

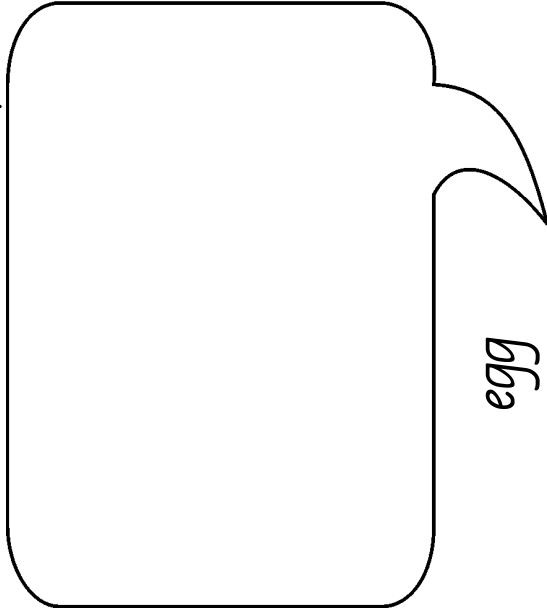

egg

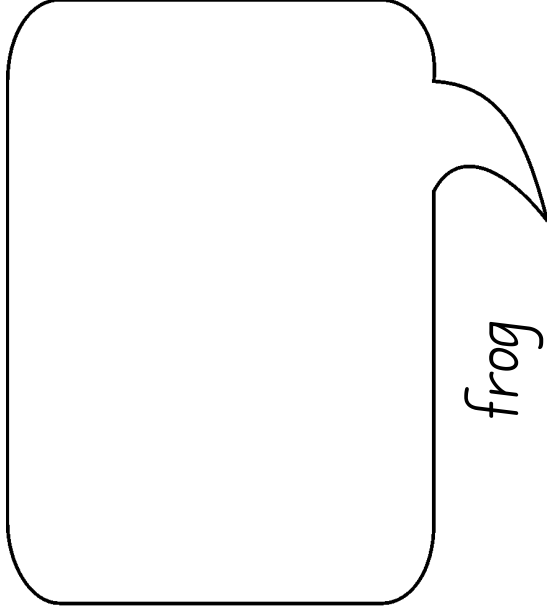

frog

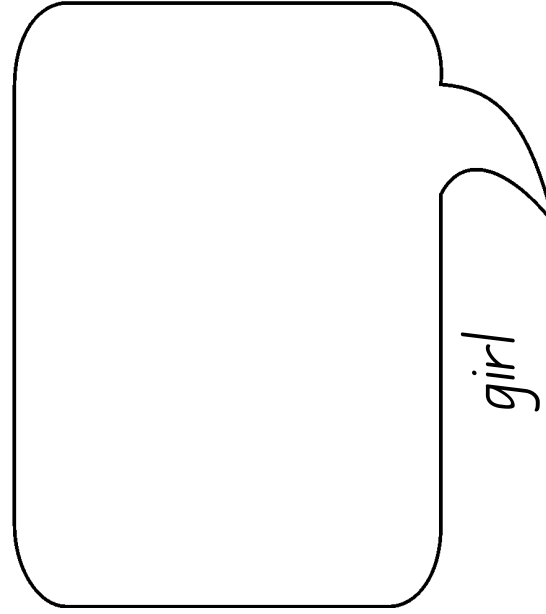

girl

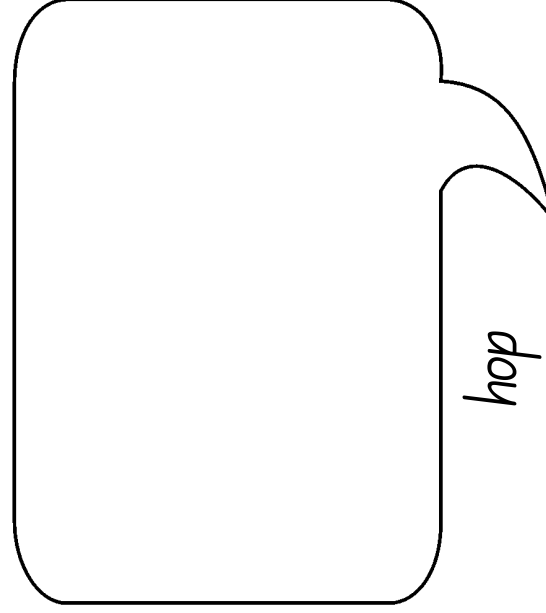

hop

Starting sounds:

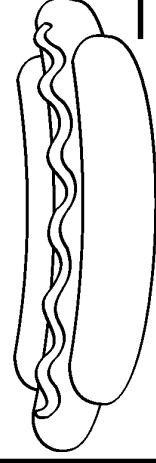
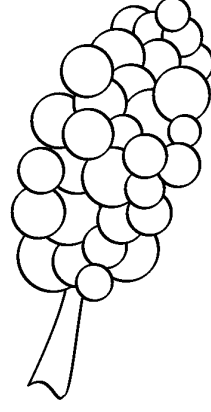
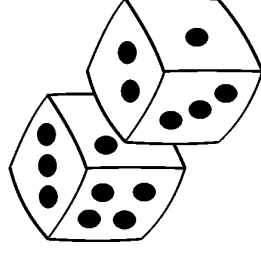
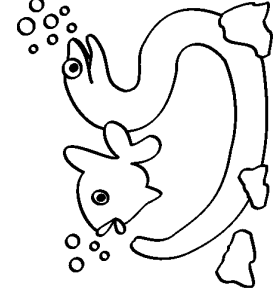

Fun With Starting Sounds and Sentences

Name: _____

Which word matches the picture?

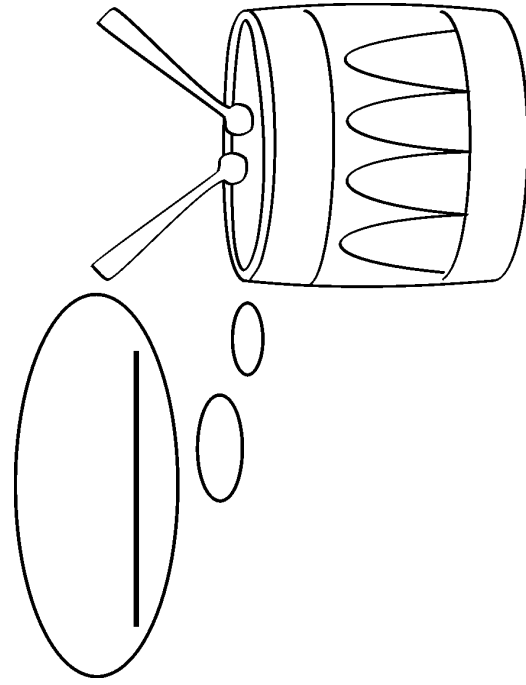

drill

drum

drip

Read and Draw

Here is a dog.

True or False?

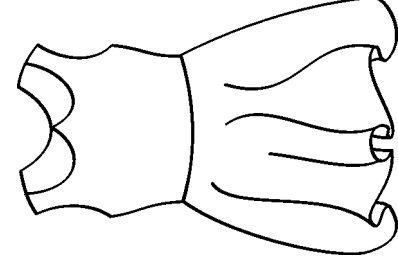

Here is a dress.

t
r
u
e

f
a
l
s
e

Which word starts with **a** ?

and

be

do

bad

Fun With Starting Sounds and Sentences

Name: _____

Which word matches the picture?

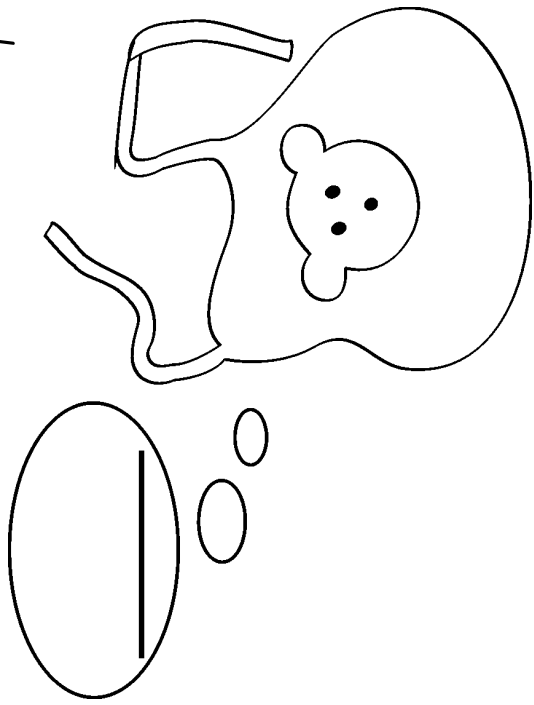

big
bib
bag

True or False?

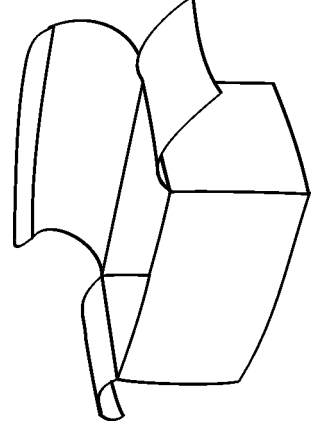

t
r
u
e

f
a
l
s
e

Here is a fox.

Read and Draw

Here is a bike.

Which word starts with **b**?

is

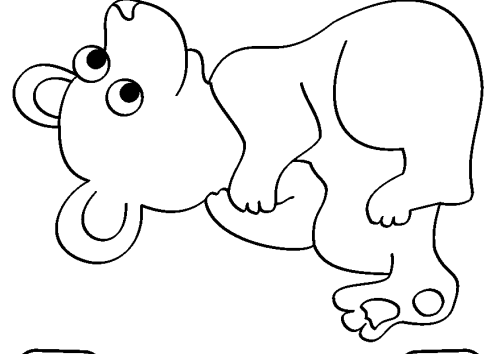

and

be

of

Fun With Starting Sounds and Drawing

Name: _____

Draw a picture for each word.



jelly fish



lion



hat



kite

Starting sounds:

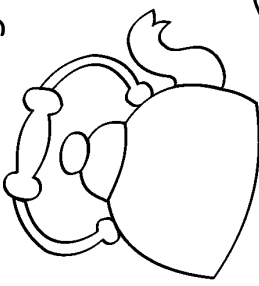



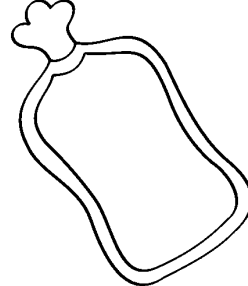



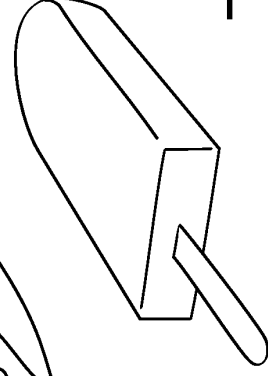

Fun With Starting Sounds and Drawing

Name: _____

Draw a picture for each word.

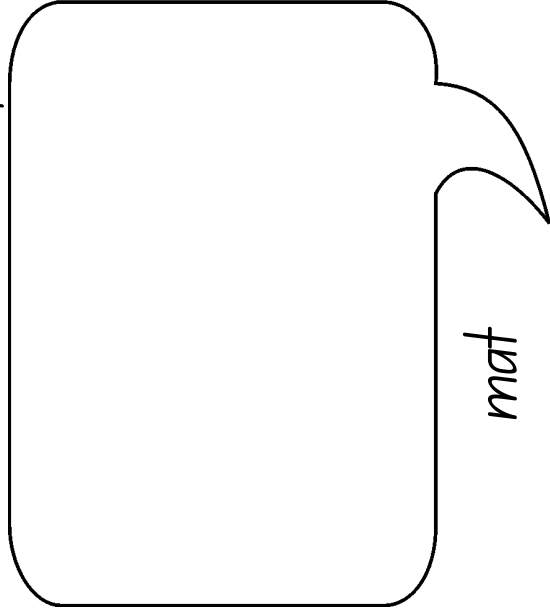

mat

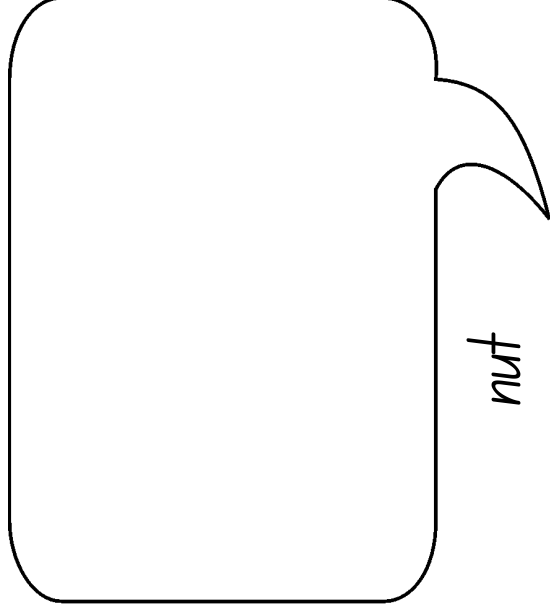

nut

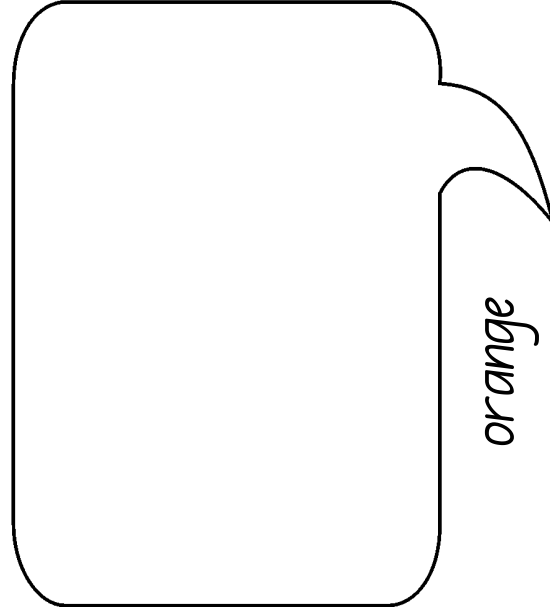

orange

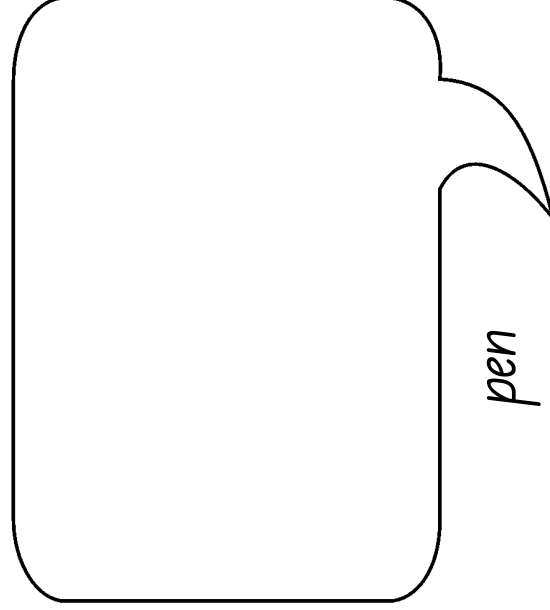

pen

Starting sounds:

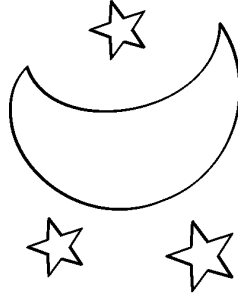
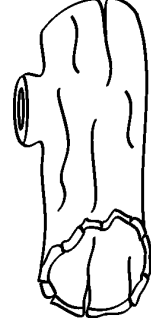
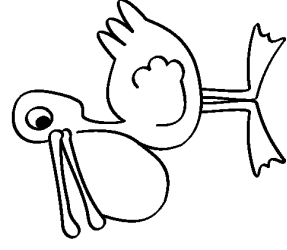
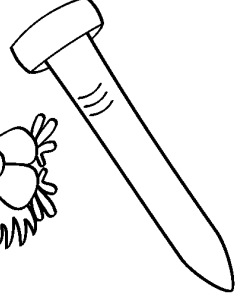
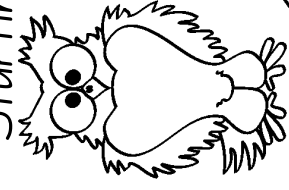

Fun With Starting Sounds and Sentences

Name: _____

Which word matches the picture?

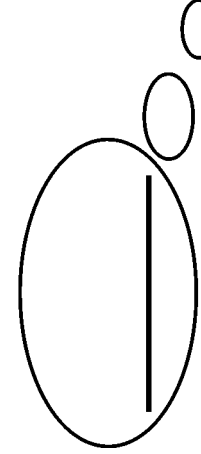

bit

boy

bat

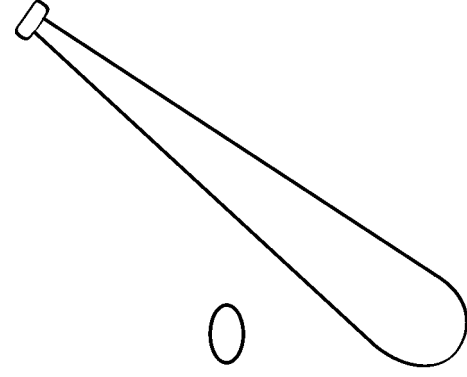

True or False?

t r u e

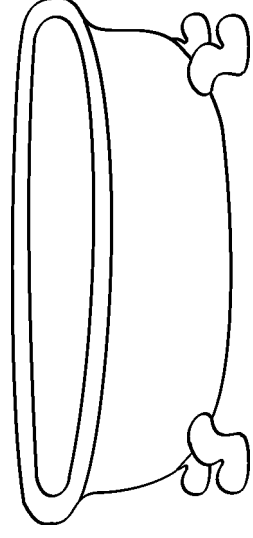

f a l s e

Here is a bus.

Read and Draw

Here is a book.

Which word starts with **a** ?

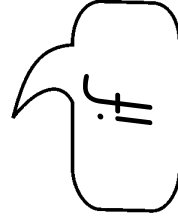
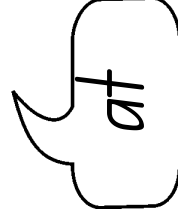
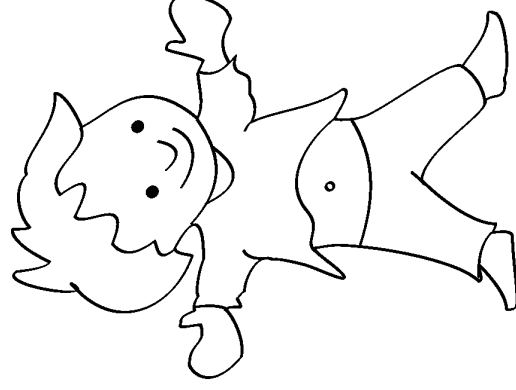
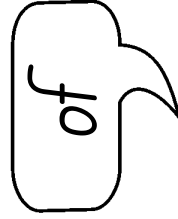
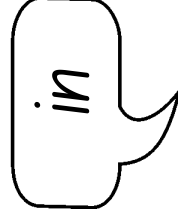

Fun With Starting Sounds and Words

Name: _____

Write the starting sounds.

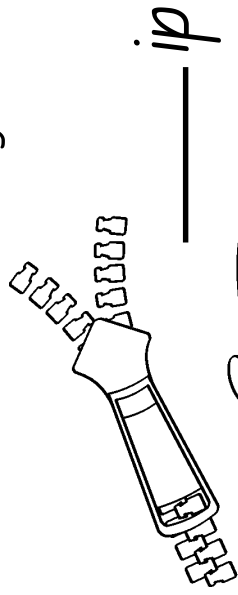

_____ ip

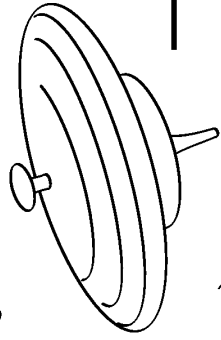

_____ op

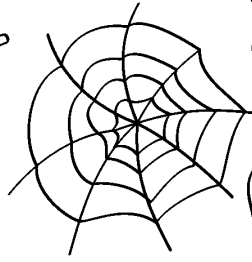

_____ eb



_____ ap

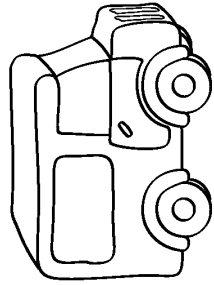

_____ an

Add (m) to these words:

_____ ap _____ ug _____ op _____ e

_____ ad _____ at _____ an _____ y

Choose a word and draw the picture.

Circle the correct answer.

Is this a mop?

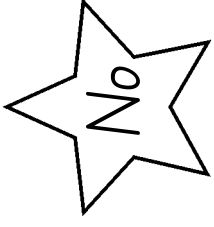
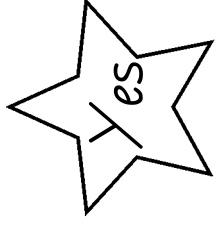
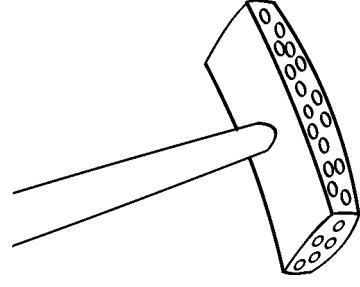

Fun With Starting Sounds and Drawing

Name: _____

Draw a picture for each word.

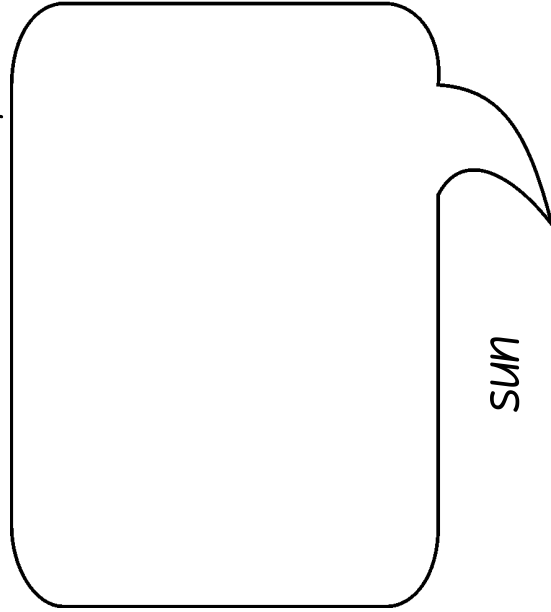

sun

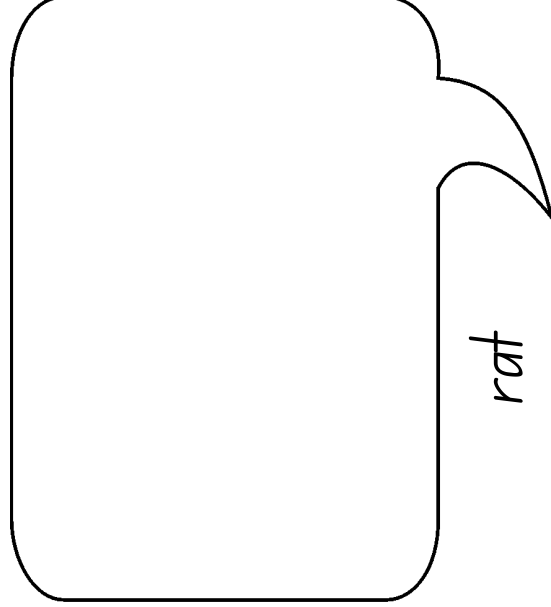

rat

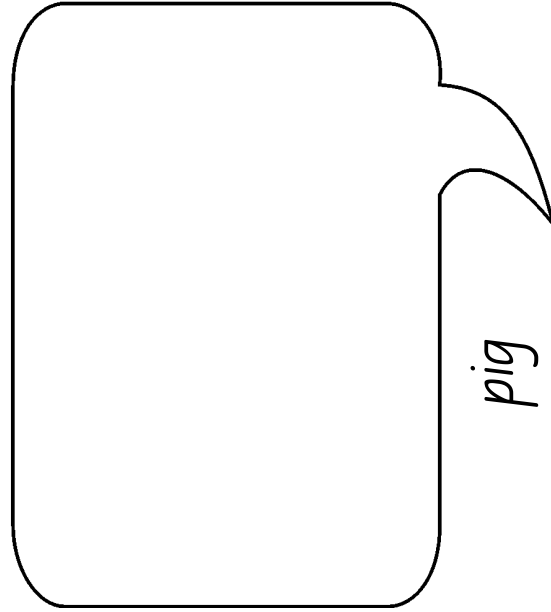

pig

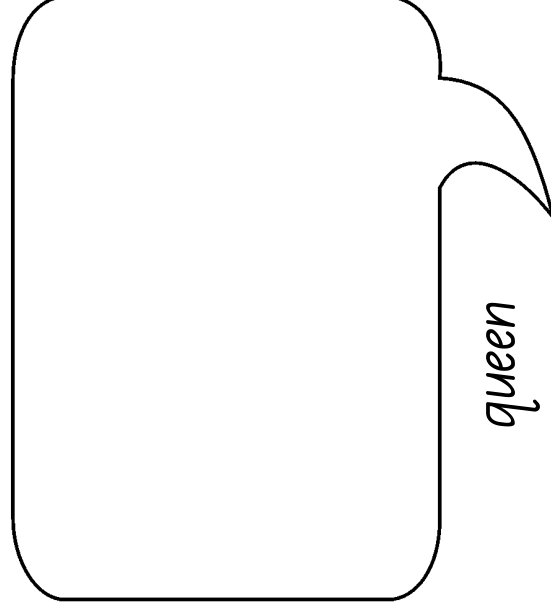

queen

Starting sounds:

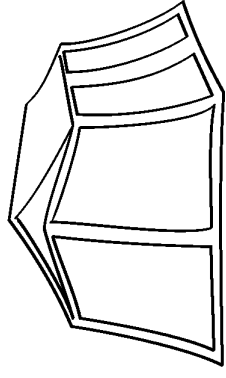
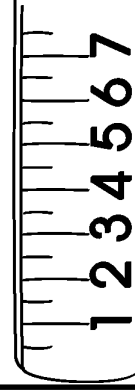
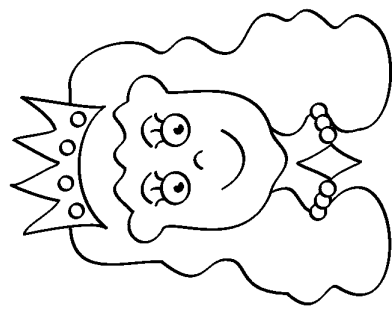
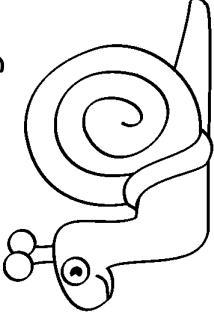

Fun With Starting Sounds and Drawing

Name: _____

Draw a picture for each word.

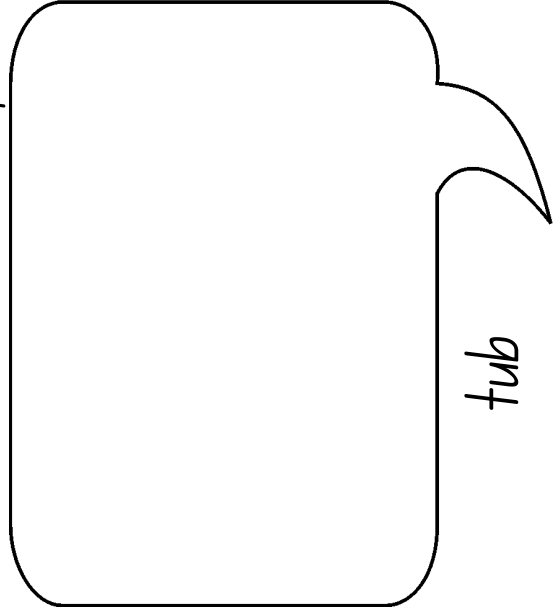

tub

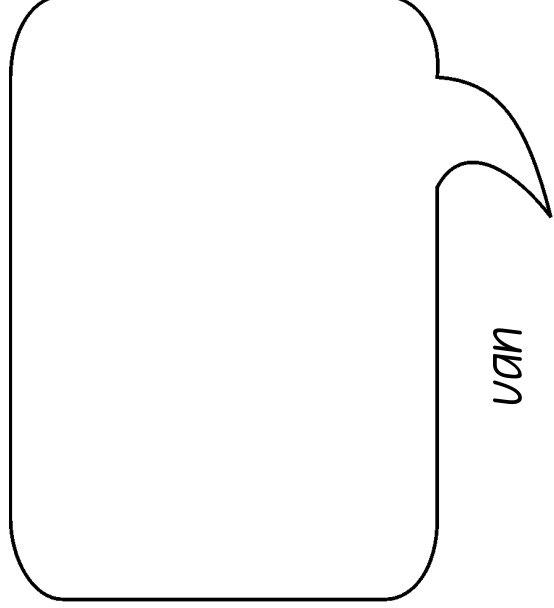

van

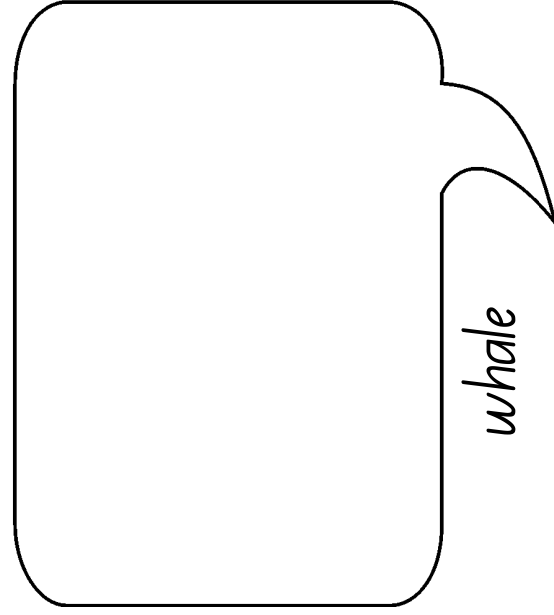

whale

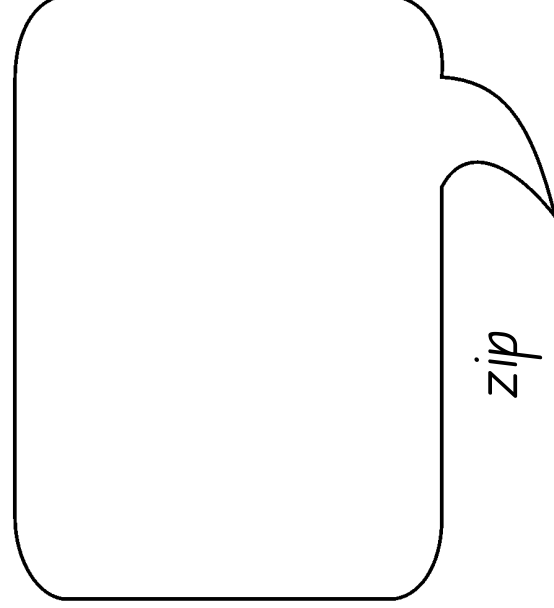

zip

Starting sounds:

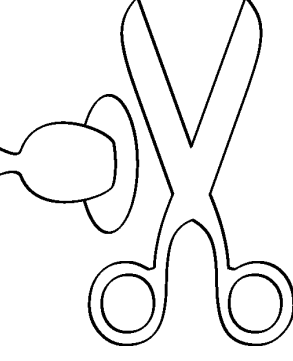
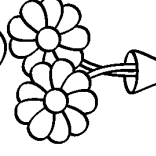
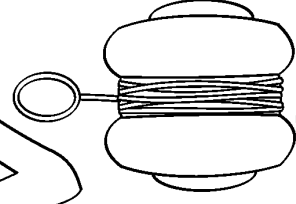
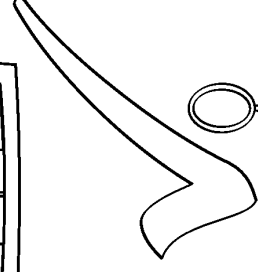
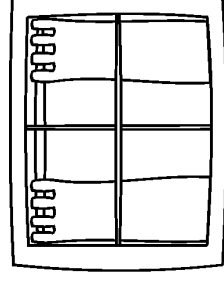

Fun With Starting Sounds and Words

Name: _____

Write the starting sounds.

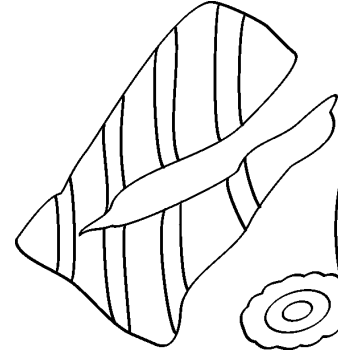

_____ ip

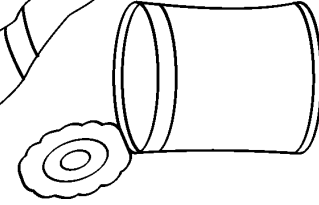

_____ in

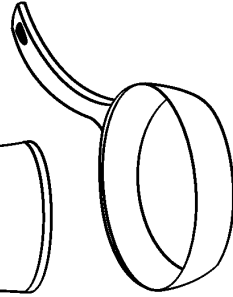

_____ an



_____ en

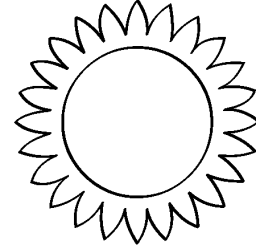

_____ un

Add **(r)** to these words:

_____ am _____ at _____ ip _____ un

_____ an _____ ug _____ od _____ ag

Choose a word and draw the picture.

Circle the correct answer.

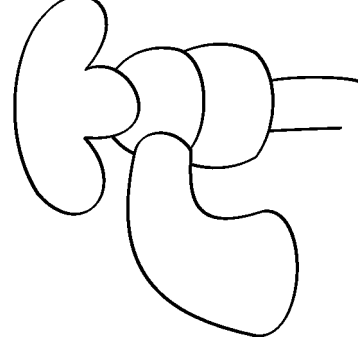

Is this a tap?

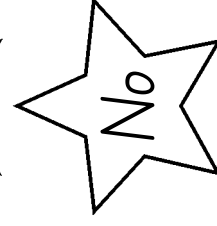

Fun With Starting Sounds and Words

Name: _____

Write the starting sounds.



ig

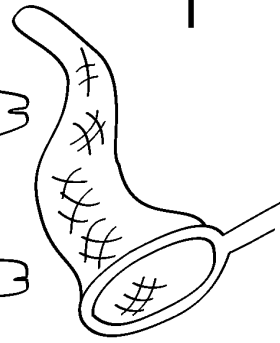

et

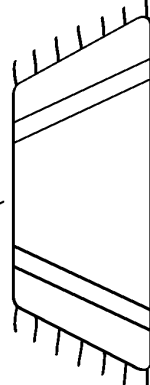

at

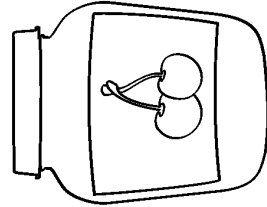

am



id

Add **(p)** to these words:

____ot _____et _____ie _____eg

____ip _____op _____up _____an

Choose a word and draw the picture.

Circle the correct answer.

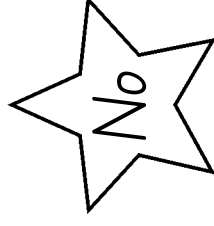
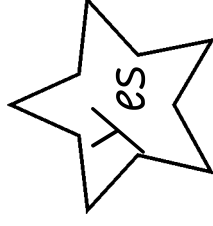

Is this a leg?

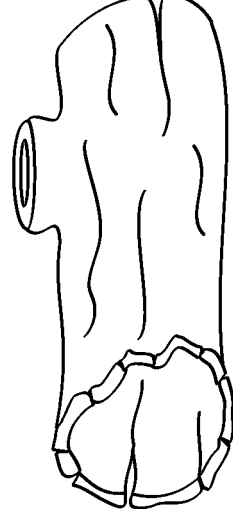

Fun With Starting Sounds and Words

Name: _____

Write the starting sounds.

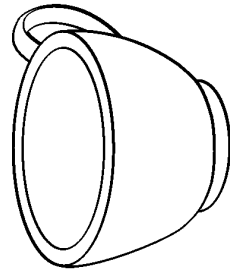

up

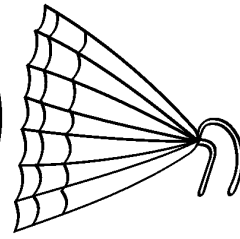

an



og

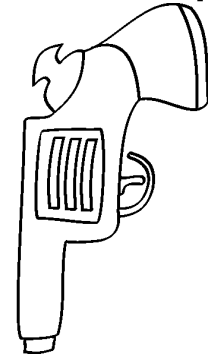

un

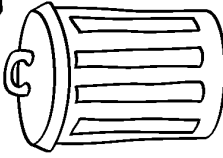

in

Add **(c)** to these words:

____up _____ot _____ar

____at _____ub _____ap _____ow

Choose a word and draw the picture.

Circle the correct answer.

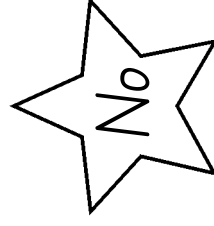
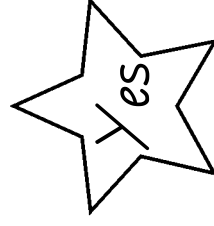

Is this a bib?

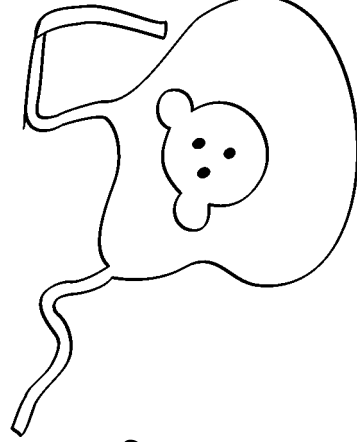

Fun With Starting Sounds and Words

Name: _____

Write the starting sounds.

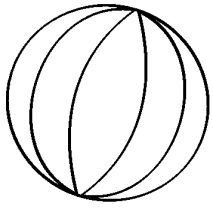

_____ all

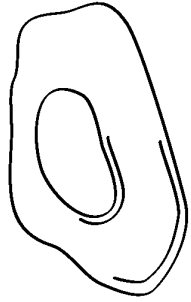

_____ gg

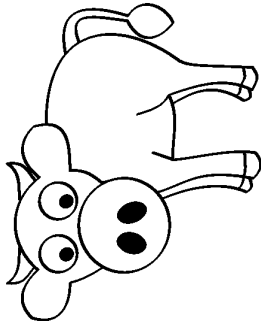

_____ ow

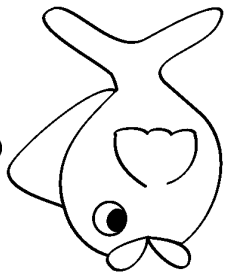

_____ ish

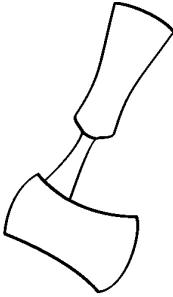

_____ xe

Add **(d)** to these words:

_____ id _____ og _____ of _____ ip

_____ o _____ ad _____ ay _____ up

Choose a word and draw the picture.

Circle the correct answer.

Is this a cake?

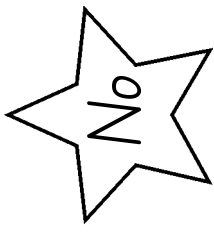
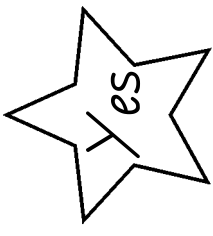
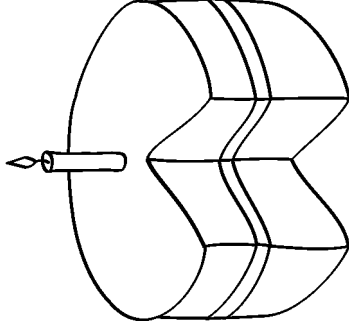

Fun With Starting Sounds and Words

Name: _____

Write the starting sounds.

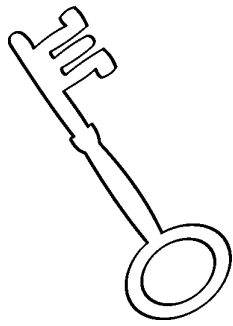

_____ ey

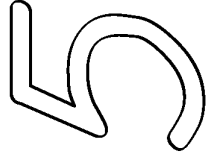

_____ ive

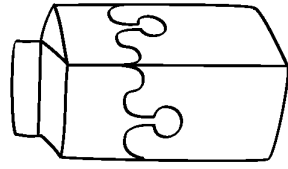

_____ ilk

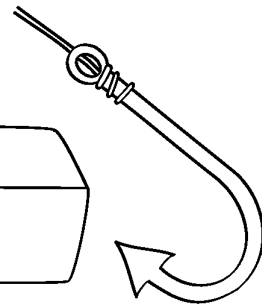

_____ ook

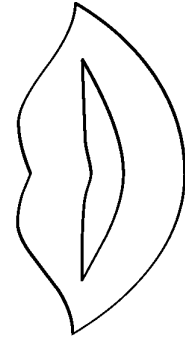

_____ ips

Add **(h)** to these words:

_____ ot _____ op _____ is _____ at

_____ it _____ ip _____ ut _____ e

Choose a word and draw the picture.

Circle the correct answer.

Is this a nut?

